



FIRE INVESTIGATION REPORT

**World Trade Center Explosion and Fire
New York, New York
February 26, 1993**

Prepared by

**Michael S. Isner
Fire Protection Engineer
National Fire Protection Association**

and

**Thomas J. Klem
Director of Fire Investigations
National Fire Protection Association**

TABLE OF CONTENTS

ABSTRACT	2
I. INTRODUCTION	7
II. BACKGROUND	10
Applicable Codes	10
The Complex	10
Primary Electrical System	14
Emergency Electrical Systems	16
Fire Protection Systems	18
Means of Egress	22
Occupant Training	23
Weather Conditions	24
III. THE EXPLOSION AND FIRE	25
Discovery and Occupant Activities	25
Fire Department Notification and Response	25
Operational Overview	30
Occupant Activities and Evacuation	31
Casualties	32
Damage	33
IV. ANALYSIS	36
Cause and Origin	36
Explosion and Fire Growth	36
Smoke Movement	38
Smoke Characteristics	42
Performance of Primary Electrical Systems	44
Performance of Emergency Electrical Systems	46
Performance of Fire Protection Systems	47
Code Analysis	49
Post-Incident Fire Protection at the World Trade Center	51
V. DISCUSSION	54

ABSTRACT

On Friday, February 26, 1993, a violent explosion ripped through a parking garage in the sub-basement levels of New York's World Trade Center complex, immediately killing six people. The explosion caused extensive damage in several basement levels and resulted in an intense fire that quickly distributed thick, black smoke to the upper levels of many of the complex's seven buildings, causing a massive evacuation. The explosion also disabled much of the fire protection systems within the complex, including the fire alarm communication system for the "Twin Towers," leaving evacuating occupants without emergency instructions during their prolonged escape. Many of the approximately 150,000 occupants within the complex were confronted with dense smoke on occupied floors and then in stairways as they began reaching the lower levels of the buildings. Further, the smoke-filled stairways were immersed in darkness when both the normal and emergency electrical power were interrupted. More than 1,000 people were injured during the evacuation of the complex, most suffering from the effects of smoke exposure. Unlike most fatal fire scenarios, however, there were no fatalities attributed to the effects of smoke despite the severe exposure to products of combustion and the lengthy evacuation time.

The World Trade Center complex includes seven high-rise buildings, a shopping mall, and several levels of underground parking. The two largest high-rise buildings are 110 stories tall and are commonly referred to as the "Twin Towers." In addition to these high-rise buildings, there is a 47-story high-rise building, a 22-story high-rise building (Vista Hotel), two 9-story high-rise buildings, and one 8-story high-rise building. Excluding the hotel, most of the occupied space within the buildings is dedicated for office use. All of the buildings, except for the 47-story high-rise building, are constructed over a plaza area that contains the 60-store shopping mall, four underground levels of public parking, and two utility levels. In addition to the large number of people working there, the complex also serves as a commuter rail station, a connecting point for thousands of commuters into and out of the city and attracts thousands of daily visitors.

A van containing explosives was parked on the B-2 level of the underground parking garage in a position adjacent to one of the towers and under the Vista Hotel. At 12:18 p.m., the explosives were detonated causing varying degrees of physical damage on all six basement levels. In the immediate area of the explosion, the floor slabs for two basement levels collapsed onto vital electrical, communications, and domestic water systems equipment for the complex. Further, masonry fire walls and fire doors separating the buildings within the complex were voided by the force of the explosion. The explosion also penetrated vertically into a first-floor public assembly area of the Vista Hotel and shattered several glass partitions that separated the hotel from the lobby area of one of the Center's towers. This penetration of the structures enabled dense, black, super-heated smoke from the explosive materials and the ensuing fire to quickly fill the lobby area and move into numerous elevator shafts.

At the same time, the smoke, greatly accelerated by the extreme temperatures and pressures of the explosion, was forced horizontally throughout the basement area and entered additional elevator shafts through doors and walls damaged by the explosion. Once in the elevator shafts, the smoke spread vertically and began to fill the occupied areas of the two towers, the Vista Hotel, and another high-rise building in the complex. The degree of smoke spread into the buildings varied according to the extent of damage in the basement areas and according to the individual building's distance from the explosion site. The most severely affected buildings were the twin towers and the Vista Hotel. In time, smoke also spread into a fourth building within the complex; however, all seven buildings in the complex were evacuated. The initial speed of the smoke spread was influenced most by the explosion, and forces associated with the "stack effect," a natural, ever-present condition in high-rise buildings. The spread of smoke to the upper levels of buildings by the "stack effect" is common in high-rise fires.

The explosion also interrupted most of the normal electrical circuits in the complex. In response to the power outage, the electrical demand was transferred automatically to some of the emergency circuits for affected areas in the towers, and diesel-powered emergency generators started automatically in order to supply power to the emergency systems.

Shortly after starting, however, the emergency generator engines overheated and shut down because components of their cooling system were damaged by the explosion. Approximately 1 hour and 15 minutes into the incident, all remaining electrical power to the affected buildings within the complex was shut down.

Once the detonation and subsequent ignition of adjacent combustibles occurred, the explosive forces and natural air movements quickly distributed products of combustion to occupied areas through horizontal and vertical openings, and soon total evacuation of the complex became necessary. Many occupants entered stairways and were confronted by the smoke. Later, due to the electrical power failure, the occupants experienced total darkness in the stairways and resorted to other means of illuminating their exit paths. The unexpected mass evacuation further influenced adequate performance of the exiting system since the stairways soon filled with people who were waiting for an opportunity to enter stairways and held doors open, thus allowing smoke from the respective floors to migrate into the stairways.

The loss of the normal electrical service and of the emergency generators also affected the standpipe and sprinkler systems for most of the buildings. The primary water supply for the standpipe systems and some of the sprinkler systems was municipal water mains and electric fire pumps. The primary water supply for the sprinkler systems in the towers was gravity tanks which were not affected. With the loss of electrical power, the primary water supply was limited to that provided by the normal pressures in the water distribution system. Furthermore, the loss of electrical power to domestic water pumps limited the capability of the sprinkler systems in the towers to that water in the gravity tanks. Fortunately, the fire did not propagate from the basement levels and thus did not challenge the performance of the remaining fire protection features.

Successful occupant response during a fire emergency in this complex is dependent upon a transfer of information from emergency personnel in the operations control center. After initial assessment of a reported fire, for example, selective evacuation of occupant floors

would be initiated as determined by the control room operator or by arriving fire suppression officers. In this incident, however, the control center was destroyed by the explosion, leaving occupants without vital fundamental information from emergency responders. As a result, the occupants' response to the fire was uncoordinated, underscoring the necessity for all building occupants to understand and be trained in proper fire safety procedures. A detailed human behavior study of the occupants' actions in this massive emergency is currently being undertaken by the NFPA.

The New York City Fire Department responded to the explosion and fire at the World Trade Center with 16 alarms, involving hundreds of fire fighters at the height of activities. This commitment represented approximately 45 percent of the New York City Fire Department on-duty resources and was the largest single response in the history of the New York City Fire Department. Several fire crews were committed to the suppression of cars and other combustible materials burning in the basement. Though the vast majority of the fire fighters, however, were committed to time-consuming tasks of search and rescue in all areas of the seven high-rise buildings and assisting in the care of escaping occupants.

During the explosion and fire and the prolonged evacuation, six people died and 1042 people were injured, though there was a real potential for many more deaths and severe injuries. Many of the injured occupants suffered from smoke inhalation but, remarkably, none died from the exposure. This occurred primarily because there was a limited amount of combustibles that were initially ignited, and because of the basement floor collapse, there was limited fire spread to adjacent materials. Because of the limited burning there was a significant dilution of the products of combustion as they moved through this massive building complex. Had there been a more continuous burning or less dilution of the smoke, it is likely that the loss of life in this tragedy would have been far greater than the six casualties who were directly exposed to the force of the explosion.

The facts of the World Trade Center incident and the lessons learned should serve as an impetus for the fire safety community to re-examine the current design philosophies and

future directions for high-rise fire technology. Prior to the incident there was no attempt to treat "mega-high-rises" such as the World Trade Center differently from other high-rise buildings with regard to reliability of fire protection system design. However, since such mega-high-rises can simultaneously expose tens of thousands of people to life-threatening conditions from a "single event," more reliable performance of fire protection components may be appropriate. Further warranting consideration is where the structures contain critical, private enterprises or government agencies, as was the case in the World Trade Center.

Although fire protection designers normally would include a "single event" scenario in their performance criteria of fire protection systems, this single event at the World Trade Center complex has initiated an active discussion as to what a "single event" scenario should include. The NFPA believes fire protection designers and code officials should perhaps broaden their responsibilities to include security issues or other such subtle changes in our society in achieving dependable and reliable fire protection system performance for such critical occupancies.

The complexity of this incident also demonstrates the importance of compliance with fundamental fire protection requirements for high-rise buildings. The growing inventory of high-rise buildings in this country should be reviewed to ensure that minimum levels of fire protection are present. Further, recent fatal high-rise building fires have demonstrated the importance of inspection and maintenance of these systems. One of the more recent high-rise fires resulted in three fire fighters losing their lives, further underscoring the importance of fire safety requirements for these buildings. Finally, owners, insurers, security, fire protection professionals, and code developers may want to re-examine fire protection designs in high-rise structures, especially where those structures accommodate large numbers of people and the economic impact is great, to ensure that the protection systems achieve a high degree of reliability during a "single event" occurrence. The NFPA's *Life Safety Code*® addresses occupant safety in both new and existing buildings; an important consideration in fundamental fire safety principles in the built environment.

I. INTRODUCTION

The National Fire Protection Association (NFPA), with the assistance of Building Officials and Code Administrators International (BOCA), investigated the World Trade Center fire in order to document and analyze significant factors that resulted in the loss of life and property. This investigation was funded by the NFPA as part of its on-going program to study technically significant fires. The NFPA's Fire Investigations Department documents and analyzes incident details so that it may report lessons learned for life safety and property loss prevention purposes.

The joint NFPA/BOCA investigation of the World Trade Center explosion and fire was conducted under an agreement between NFPA and the three model building code organizations to investigate significant structural fires and other emergencies throughout the United States. In addition to BOCA, the other cooperating model building code groups are the International Conference of Building Officials (ICBO) and the Southern Building Code Congress International (SBCCI). The three model building code groups typically provide technical staff support for on-site field work and building code analysis.

After the NFPA became aware of the explosion and fire, Michael S. Isner, Fire Protection Engineer, was dispatched to Manhattan, New York, to perform an on-site study of this incident. Entry to the fire scene and data collection activities were made possible through the cooperation of the Port Authority of New York and New Jersey and the New York City Fire Department. During his 10-day, on-site study, Mr. Isner was joined and assisted by Mr. Thomas J. Klem, Director of NFPA Fire Investigations, and Mr. Bruce Larcomb, P.E., P.S., BOCA Regional Manager. The NFPA and BOCA investigators were assisted by representatives of The Port Authority of New York and New Jersey, the New York City Fire Department, Cigna Property and Casualty Companies, and the U.S. Department of Labor, Occupational Safety and Health Administration (OSHA).

The data gathered during the on-site study and the subsequent analysis of that information are the basis for this report. Information and details regarding fire safety conditions are based on the best available data and observations made during the data collection and on additional information provided during the report development process.

It is not the NFPA's intention that this report pass judgment on, nor fix liability for, the loss of life and property resulting from the World Trade Center fire. Rather, the NFPA intends that its report present the findings of the NFPA data collection and analysis effort and highlight factors that contributed to the loss of life or property.

Current codes and standards were used as criteria for this analysis so that conditions at the World Trade Center on the day of the fire could be compared with current fire protection practices. It is recognized that these codes and standards may not have been in effect during construction or operation of the center. The NFPA has not analyzed the World Trade Center regarding its compliance with the codes and standards that were in existence when the complex was built or during its operation.

The cooperation and assistance of Mr. Eugene Fasullo, P.E., Director of Engineering and Chief Engineer; Mr. Alan Reiss, Special Assistant to the Director; Mr. Gerry Cummiskey, Administrator Risk Control; and many other staff with The Port Authority of New York and New Jersey are acknowledged and appreciated.

The cooperation and assistance of Anthony Fusco, Chief of Department; John J. Hodgens, Chief of Fire Prevention; Kenneth Cerretta, Deputy Commander Manhattan; Tom Lally, Deputy Chief Bureau of Fire Prevention; and David Corcoran, Deputy Chief 1st Division, of the New York City Fire Department are also acknowledged and appreciated.

Thanks are given to Mr. Jeffrey R. Stump, CSP, Northeast Manager, Loss Control Services, Cigna Property and Casualty Companies. Mr. Stump provided notable assistance during the initial on-site data collection and during subsequent activities.

The contributions of Mr. Bruce Larcomb, P.E., P.S., Regional Staff Manager, are recognized and appreciated. In addition to providing assistance in the data collection phase, he was instrumental in preparing the sections of the report that pertain to the BOCA/National Building Code, and he actively participated in the review of this report.

Also, the assistance provided by Mr. Michael Marshall, Civil Engineer, OSHA, Washington D.C.; Mr. William C. DuComb, Safety Specialist, OSHA, Marlton, NJ; and Ms. Linda Forsyth, Area Director, and others at the OSHA Manhattan Area Office is appreciated.

Finally, we wish to thank Maureen Tobin, Department Secretary, for her support and assistance in the preparation of this report.

II. BACKGROUND

Applicable Codes

The World Trade Center complex is owned and operated by The Port Authority of New York and New Jersey, a self-supporting agency of the two states. The Port Authority is aware of the content of the codes promulgated by the National Fire Protection Association (NFPA), New York City, New York State, and the Building Officials and Code Administrators International (BOCA), though it has not adopted a specific fire safety code from any of these organizations or authorities. The Port Authority, however, considers the requirements contained in the NFPA, New York City, and BOCA codes when developing designs and policies within the organization.

The Complex

The World Trade Center complex is a seven-building complex located in lower Manhattan. The complex was developed and constructed by The Port Authority of New York and New Jersey at the request of the two states to serve as headquarters for international trade within the bi-state port area. (See Figure 1.) Buildings 1 - 6 (commonly referred to as One World Trade Center through Six World Trade Center) are surrounded by a five-acre, landscaped, open-air plaza. These buildings and the plaza are constructed atop a 16-plus-acre base structure. Seven World Trade Center is across Vesey Street. The center contains approximately 12 million square feet of rentable office space, including two million square feet of office space in Seven World Trade Center.

The World Trade Center opened for first tenancy in December 1970. It has an average daily population of 150,000; this population includes an estimated 60,000 people working in the World Trade Center, and another 90,000 business persons and other visitors who come to the Center. The businesses located at the World Trade Center are engaged in almost every conceivable kind of international commerce activity, including import, export, freight forwarding, customs brokerage, international banking and finance, insurance, transportation, trade associations, and local, state, federal, and foreign government offices. Because of the diverse nature of the numerous occupancies, interruption of the enterprise

could impact on world political or financial affairs. At the time of the explosion and fire, almost all of the rentable space within the Center was occupied by more than 1,200 firms and organizations.

One and Two World Trade Center (Towers 1 and 2) are 110-story office buildings, and each rises to a height of 1,350 feet. These towers are the tallest buildings in New York City and the second tallest buildings in the world. Each floor of the two tower buildings is approximately one acre in size. The floors are column-free, assuring maximum flexibility in layout.

The Manhattan headquarters for the Port Authority's administrative staff is located in Tower 1. The "Windows on the World" restaurant is located on the 107th floor of Tower 1 and is the newest addition to the extensive private dining facilities at the Center. In addition to its dining facilities on the 107th floor, this restaurant operates a ballroom located on the 106th floor. The ballroom can accommodate up to 1,000 guests for receptions.

A 360-foot television mast constructed on top of Tower 1 supports 10 primary television antennas, numerous auxiliary antennas, and a master FM antenna. The television stations in the metropolitan area, including a public television station, broadcast from the mast. Two UHF radio stations also use the mast for their transmissions.

Tower 2 has administrative offices for several State of New York agencies. In addition, "The Observation Deck," a public assembly area, is located on the 107th floor of this tower. Each year, an estimated 1.5 million people visit The Observation Deck which is comprised of an enclosed deck on the 107th floor, a History of Trade exhibit, and a rooftop promenade – the highest outdoor viewing platform in the world at 1,377 feet – above the 110th floor. Other amenities offered are a quick-service restaurant and gift shop.

Tower 2 also contains an exchange for the New York Telephone system. This exchange provides local and long distance telephone switching for some of the Manhattan area. In addition, this exchange services the telecommunication systems for air traffic control at New York's three major airports.

Three World Trade Center (Building 3) is the Vista Hotel. This is a 22-story, 825-room, luxury hotel. Four World Trade Center (Building 4) is a 9-story office building housing New York City's new headquarters for commodities trading. Five World Trade Center (Building 5) is another 9-story high-rise building containing a variety of businesses. Six World Trade Center (Building 6) is an 8-story high-rise office building referred to as the Customs House. The U.S. Customs Service shares this high-rise with other vital federal government agencies. Building 7 is a 47-story structure providing office space for many companies.

The Concourse is the first level below the open-air plaza surrounding Buildings 1 - 6. This Concourse is the largest enclosed shopping mall in Manhattan with an estimated 60 shops, restaurants, and services available. The Concourse is also the main interior pedestrian circulation level for the complex.

Below the Concourse, there are six basement levels, i.e., B1 - B6. The B1 and B2 levels exist below Buildings 1 - 6. Truck loading docks for these six buildings are located on the B1 level. The police and fire command center for most of the complex, maintenance shops and offices, several mechanical rooms, and other rooms associated with the high-rise buildings above are also located on the B1 level. An enclosure for the Broadway - 7th Avenue (#1/9) lines of the New York City Transit Authority passes through the B1 level¹ and as a result, the B1 level below Buildings 4 and 5 is separated from the B1 level below the rest of the complex. (See Figure 2.) Two vehicular tunnels run below the subway enclosure and allow trucks to drive between the B1 levels on each side of the subway tracks. The B2 levels under Towers 1 and 2, the Vista Hotel, and the Customs House contain public parking and utility areas; the B2 level under Buildings 4 and 5 contain only utility spaces.

¹ This line is commonly referred to as the IRT which is derived from Intraborough Rapid Transit - the former operating company for this line.

Four more basements levels (B3 - B6) exist below Towers 1 and 2, the Vista Hotel, and the Customs House only. The B3 and B4 levels contain additional public and private parking areas. These parking areas in conjunction with the B2 level parking areas allow the complex to accommodate approximately 2,000 cars. Similar to the B1 and B2 levels, the B3 and B4 levels contain many utility areas and rooms associated with the high-rise buildings in addition to the parking areas. Levels B5 and B6 contain more utility areas and a major terminal for the Port Authority Trans-Hudson (PATH) trains.

The World Trade Center has more than 240 elevators, including those servicing the sub-levels, throughout the complex. Several elevators service each floor, and these elevators have been grouped into banks. To reduce the potential elevator service interruptions, the electrical power for one-half of a bank of elevators is provided by one substation with four high-voltage feeders, and the electrical power for the other elevators in the same bank is provided by a different substation receiving electrical power from four separate high-voltage feeders. Thus, the loss of any one electrical feeder would not result in total loss of service to an entire elevator bank.

A "sky lobby" system is used to coordinate the service of the 99 elevators in each tower, and this system separates the passenger elevator service into express and local. (See Figure 3.) Each of the 23 express elevators in each tower (See Figure 4.) is capable of handling 55 people; has a 10,000-pound capacity, and travels from the lobby area to sky lobbies on the 44th and 78th floors. Passengers can then transfer to local elevators serving groups of floors. In addition to the passenger elevators, there are several freight elevators that service groups of floors, such as all floors in the top two-thirds of the building. These freight elevators have door openings onto all floors in the zone being serviced by the elevator.

Only three elevators in each tower, one freight and two passenger, traverse the entire height of the building. The freight elevator has door openings on all floors and basement levels. One of the passenger elevators that traverse the entire building has door openings

on every floor between the 78th floor and the top of the building, and it has openings in the basement levels and openings on a few floors in the lower two-thirds of the building. This passenger elevator is used as an additional freight elevator. The second passenger elevator that traverses the entire building has door openings only on the B1 level, Concourse level, 44th floor, and 107th floor. Due to the minimum number of door openings, this elevator is used only for passenger service.

Primary Electrical System²

Consolidated Edison provides 13.8KV electricity to all of the World Trade Center buildings except for the Vista Hotel through a ground level substation located near the Barclay Street (north) entrance/exit to the underground parking garage.³ Prior to the fire, the peak load provided by the substation servicing the complex was 84 megawatts for all buildings (except the Vista Hotel), the Concourse level, all basement levels and the refrigeration plant. Eight sets of service conductors carry this load from the substation to the complex. Overcurrent relays that disconnect the service conductors are provided at the substation.

Service conductors entering the complex are routed through a concrete encased duct bank which is located below an entrance/exit ramp for the B1 level. Once inside the complex, the duct bank makes a vertical transition from below the entrance/exit ramp to the B1 level ceiling. Still enclosed in concrete, the ceiling-level duct bank enters the service equipment vault, called the primary distribution center (PDC). Once inside the PDC, the service conductors drop into eight switchboards which are grouped into pairs and are separated by gypsum wallboard partitions. Electrical power from the PDC is provided to Towers 1 and 2, Buildings 4 and 5, the Customs House, the Concourse level, and to all basement levels (see Figure 5) by several electrical feeders. These feeders are protected by 1200-ampere

² This report describes the primary electrical system as it was designed and installed before the fire and explosion. This discussion does not include details regarding numerous changes that were made to the electrical system after the incident.

³ Consolidated Edison provides electrical power to the Vista Hotel via a completely separate substation.

circuit breakers with protective relays to disconnect the power when a fault occurs. The feeders for Building 7 are tapped off of the Building 4 feeders; therefore, the substation relays protecting Building 4 also protect the feeders for Building 7.

The PDC-supplied electrical systems are designed so that electrical power to each building served is provided through more than one feeder. The substations for buildings in the complex are designed such that full electrical service will not be interrupted in any building even with the loss of two 13.8-volt electrical service conductors. Though some electrical feeders are routed differently, most are routed in the ceiling/floor assembly between the B1 and B2 levels. As a result of this type of installation, the feeders are encased in concrete over the distance to their respective substations throughout the complex.

For electrical design purposes, Towers 1 and 2 have been subdivided into two vertical sections, i.e., Tower 1 — north and south sides; Tower 2 — east and west sides. Each vertical section is supplied by four electrical substations; one substation in each of the mechanical equipment rooms (MER) on the 7th, 41st, 75th, and 108th floors. Thus, Tower 1 and Tower 2 each have a total of eight electrical substations.

The arrangement of substation equipment is the same in both towers; that is, each substation has four air-cooled transformers. The transformers are rated as 1500KVA, 3 phase, 13.8KV-480/277 volt. Each is provided with a 600-ampere, 15-KV primary, no-load disconnect switch on the primary side and a 2500-ampere circuit breaker on the secondary side.

Four feeders from the PDC supply electricity to each vertical section of the tower. Each feeder supplies electricity to one transformer in each substation within a vertical section. For example, Feeder A1 supplies electricity to one transformer in each substation for the north side of Tower 1. Similarly, Feeder A2 provides electricity to another transformer in the substations on the north side of Tower 1. According to this design scheme, each feeder will supply four transformers.

The main difference in electrical design between the towers is that Tower 2 has two additional feeders. These feeders supply a substation on the 43rd floor. The transformers in this substation are dedicated and provide power to a tenant area.

Emergency Electrical Systems

All buildings in the complex have numerous emergency systems requiring electrical power. These systems include, but are not limited to, emergency lighting in all exit stairways and corridors, public address systems, fire detection and alarm systems, fire pumps, at least one elevator in each elevator bank, fire fighter telephones in the stairways, the communications transmission equipment installed on the antenna on Tower 1, and normal telephone systems.

Many sources of electrical power have been provided for the emergency systems. The primary power supply for emergency systems in the complex is the normal electrical power provided by Consolidated Edison, and this power supply is backed up by several emergency generators located in different areas throughout the complex. Emergency generators installed in the Vista Hotel provide power to the emergency circuits in that building only. Similarly, emergency generators installed in Building 7 provide electrical power to emergency circuits in that building only. New York Telephone provides separate emergency generators dedicated to the normal telephone equipment, telecommunication circuits throughout the complex, and telephone switching equipment for the Manhattan exchange. To ensure that there is no interruption of telephone service during emergencies, New York Telephone also provides batteries to maintain electrical power in the event that the emergency generators fail.

The backup power supply for emergency circuits in Towers 1 and 2, Buildings 4 and 5, the Customs House, the Concourse level, and all basements levels is six emergency generators located on the B6 level of the complex. The specification data for each

generator are 1250KVA, 480/277 volts, 4wire, wye connected, 1504 amperes, 1200KW continuous-duty rated. When the transfer switch senses a drop in voltage to a predetermined level, the emergency generator system will activate all six generators even though only four are necessary to carry the design load for the complex's emergency systems. The generators are automatically synchronized to operate in parallel ready to deliver 5000KVA of energy to emergency loads. The six generators have been configured so that all of the complex's emergency electrical demands can be met even if one generator is out of service for maintenance and another generator simultaneously fails to start.

The diesel engine drivers for the emergency generators are water cooled. Water tapped from the building's domestic water supply is circulated through heat exchangers which remove heat from the coolant circulating in the operating engines. Manually operated valves have been provided so that cooling water can be tapped from a system that brings Hudson River water into the complex for other purposes. After passing through the heat exchanger, the domestic water is discharged into a drain, and the Hudson River water is returned to the river.

In addition to the emergency generator backup, Towers 1 and 2 have been provided with an "alternate electrical system" which provides electrical power to some emergency systems. As indicated earlier, Tower 1 and Tower 2 are divided into two vertical electrical zones. Power is provided to areas in these zones by separate feeders. In the event that normal electrical power is interrupted to an area, switching gear will reroute normal electrical power from an unaffected vertical zone to the areas affected by the power outage. (See Figure 6.) The alternate electrical system will provide power to circuits for emergency lighting, fire detection systems, public address systems, fire alarm systems, fire suppression systems supervisory equipment, and communication systems. The alternate electrical system does not provide electrical power to elevator or fire pump motors. Electrical power for these high-load motors is provided by the normal electrical system or by the emergency generators.

Fire Protection Systems

Due to the size and complexity of the World Trade Center, numerous fire protection systems have been installed, and these systems are monitored at several locations. All fire protection systems for the Vista Hotel, the Customs House, and Building 7 (across Vesey Street) are monitored at separate control centers which are located in and dedicated to each of the buildings, respectively. The World Trade Center also has an Operations Control Center (OCC) located on the B1 level in an area close to Tower 1 and the Vista Hotel. The OCC is staffed 24 hours a day and operators monitor the fire protection systems for Towers 1 and 2, Buildings 4 and 5, the Concourse level, and all basement levels.

Each floor in Towers 1 and 2 and Buildings 4 and 5 is equipped with a fire alarm box designed for two-way vocal communication. The activation of this box automatically sounds an alarm in the OCC and sends a signal to the New York City Fire Department. The fire department signal does not include information regarding the location within the complex. Therefore, responding fire department personnel must contact the OCC operator to determine the area in which the signal originated.

The OCC operator can talk directly to the person at the manual pull station and can provide instructions as necessary. If the OCC operator believes that the situation warrants alerting occupants in other areas of the building, he/she can activate the fire alarm system, which flashes the lights in tenant areas and emits a warble tone via indicating devices in the core areas. The warble tone is also transmitted in the ducts for the air handling system, and the ducts carry the warble tone into tenant areas. Following the warble tone, the OCC operator will use a public address system to make announcements and to provide instructions to the occupants on a specific floor or on a selected group of floors within a building. The OCC operators also can make simultaneous announcements to occupants of a selected building or to all occupants in Towers 1 and 2 and Buildings 4 and 5. The speakers for this public address system are provided in core areas and in the stairways of Towers 1 and 2 and Buildings 4 and 5. The OCC operator has written scripts for the standard announcements that are to be read during various emergency scenarios.

Ionization-type smoke detectors in Towers 1 and 2 and Buildings 4 and 5 are located near the return-air registers located in core areas and inside the HVAC system ducts in the mechanical rooms. The activation of a smoke detector associated with the HVAC system will stop fans in the system and will notify the OCC. The HVAC systems are equipped with an emergency exhaust system and the controls for this system will override the automatic shut-down controls associated with the smoke detection system. The emergency exhaust system is only to be activated upon the order of the fire department incident commander.

Ionization-type smoke detectors are also located in all elevator lobbies in Towers 1 and 2 and Buildings 4 and 5. The operation of a smoke detector in an elevator lobby will send a signal to the OCC and will cause the elevators servicing the zone involved in the alarm activation to return automatically to a designated floor. In addition to being recalled by the activation of smoke detectors, the elevators can be manually recalled using a fire fighter's keyed switch. According to the New York City Fire Department, the elevators complied with the ASME A17.1 Standard, *Safety Code for Elevators and Escalators*.

The two towers were constructed with a standpipe in each of the three stairwells. (See Figure 7.) These standpipes have two water supplies. The primary water supply is municipal water which is provided through a dedicated fire main looping around most of the complex. Two remotely located high-pressure, multi-stage, 750-gpm, electric fire pumps take suction from the New York City municipal water supply and produce the required operating pressures for the loop main.

Each tower has three electrical fire pumps which provide additional pressure as water for the standpipes is pumped up through the tower. The first pump, located on the 7th floor, receives the discharge of the loop main fire pumps. This pump moves water up to the 41st floor where another 750-gpm fire pump is located. The fire pump on the 41st floor, in turn, supplies water to a third 750-gpm, electric fire pump located on the 75th floor. Each fire pump can produce sufficient pressure to supply water to the fire pump two levels above itself in the event that any one pump in the series should fail to operate.

The second source of water supply for the standpipes are several 5,000-gallon tanks which are filled by the domestic water supply. The storage tanks for each tower are located on the 110th floor, 75th floor, and 41st floor; Tower 1 also has a storage tank on the 20th floor. The top three tanks supply water directly into the standpipes; the lowest tank (located on the 20th floor of Tower 1) supplies water to the loop main and this water would, in turn, be available to the standpipes. In addition to the second water supply, numerous fire department connections have been installed around the complex.

Pressure in the standpipe hose outlet is regulated by restriction plates that are installed at the connection for the 1-1/2-inch unlined linen hose which is provided in all three stairways at the floor landings. These hose lines are equipped with 3/4-inch straight tip nozzles. A cabinet containing two air-pressurized water (APW) fire extinguishers is also provided in the stairways at each landing.

Telephones which allow fire fighters to communicate with fire pump operators in pump rooms are provided in Towers 1 and 2 and Buildings 4 and 5. These telephones are in locked cabinets which are located next to the standpipe. In both towers, the telephones are on the odd floors located in Stairway B and on the B1, B4, and B6 levels. In Buildings 4 and 5, the telephones are located on odd floors in all stairways. These telephones are also located on the Concourse level below Buildings 4 and 5 and on several basement levels below Building 5.

During the original construction, the center was equipped with automatic sprinklers in all basement areas, in the Concourse level tenant spaces,⁴ and on all floors of Buildings 4 and 5 and the Customs House. A dedicated loop main was installed and that main still

⁴ Sprinklers were not installed in public areas on the Concourse level. These areas included the large corridors between stores on the concourse level mall and the lobby areas for Tower 1 and Tower 2.

provides water to all of these sprinkler systems. Similar to the standpipe system's loop main, the sprinkler system's dedicated loop main receives water through two remote connections to the gridded New York City municipal water supply and is pressurized by two 750-gpm electric pumps. In addition, the sprinkler system loop main is provided with several siamese connections so the fire department can support these systems.

Through the years, a few localized automatic sprinkler systems or other types of automatic fire suppression systems were installed in Tower 1 and Tower 2. All of these systems were installed in tenant spaces according to the special needs of tenants and were supplied by the domestic water systems.

In 1981, a combined project for asbestos removal and sprinkler installation was begun. During this project, automatic sprinklers were to be retrofitted in all tenant and common spaces in the towers. This project also incorporated any previously installed sprinkler systems into the retrofitted system. At the time of the fire, 90 percent of the occupant areas in Tower 1 (closest to the explosion) were protected with automatic sprinklers and nearly 100 percent of the occupant areas in Tower 2 (farthest from the explosion area) had been protected with automatic sprinklers.

The water supply for the sprinkler systems in each tower are similar. Sprinkler systems protecting the 99th floor through the 110th floor are supplied by a 500-gpm electric fire pump that draws from a tank for the standpipe system. The sprinkler systems protecting the 31st through the 98th floors are supplied by a 10,000-gallon tank installed on the top floor of the tower. The building's domestic water system is used to fill this tank. Sprinkler systems protecting the 30th floor and areas below are supplied by a 5,000-gallon tank installed on the 41st floor and the domestic water system is also used to fill this tank. Auxiliary piping between the towers allows water from the lowest tank in one tower to be used during

the operation of the sprinkler systems in the bottom 30 floors of the adjacent tower, thus ensuring that all sprinkler systems in the towers have a tank supply of 10,000 gallons. This water supply is consistent with the New York City requirements.

Fire department connections have also been provided so that fire fighters may complement the primary and secondary water supplies for the sprinkler systems. The fire department connections allow fire fighters to pump directly into the sprinkler systems protecting the first 30 stories in both towers. To support the sprinkler systems protecting areas on the 31st - 98th floors, the fire department pumps into the building's standpipe system and a roof level connection allows water to enter the sprinkler system piping. Pressure regulating valves are provided in this system.

The Vista Hotel and Building 7 are also protected by automatic sprinklers. The sprinkler systems for these buildings, however, are completely independent of all other sprinkler systems in the complex.

Fire carts, for use by members of the center's fire brigade, are parked on the Concourse level and on the 44th and 78th floor sky lobbies for each tower. These carts are equipped with hoses, nozzles, self-contained breathing apparatus, turnout coats, forcible entry tools, resuscitators, a first-aid kit, and other emergency equipment.

Means of Egress

Every building in the complex has at least two means of egress from all occupiable areas. These exits discharge to several areas including outside plaza areas, the Concourse area, the atriums for the towers and, in many instances, directly to grade.

Each of the towers has three enclosed stairways which are located in the core area of the tenant floors. (See Figure 7.) Two stairways (Stairways A and C) discharge onto the mezzanine level in the atrium/lobby area of the respective tower. Several doors provide direct access to the exterior of the building from the mezzanine. The third stairway (Stairway B) in each tower discharges into the atrium/lobby on the Concourse level.

Stairway B in both towers also continues past the Concourse level and provides a means for occupants of all six basement levels to reach the Concourse level. Several exits directly to the outside are available on this level.

The other high-rise buildings also have multiple exit stairways for each floor. Some of these discharge directly to the building exterior and other stairways discharge onto the Concourse level. The sub-basement levels had numerous enclosed exit stairways. Similar to the high-rise buildings, the exit stairways discharge either to the exterior of the complex or to the Concourse level.

All doors providing access to the towers' exit stairways allow egress at all times. However, many doors within the towers' exit stairways are locked to prevent occupants that are in the exit stairways from re-entering most occupant floors. With few exceptions, unlocked re-entry doors are provided at four-floor intervals or less; in some areas re-enterable doors are located on several consecutive floors. On the interior of every stairway door there is a sign stating the floor level and indicating whether the door on that level is re-enterable. The sign on all locked doors also states the floor level for the next closest re-enterable doors, both above and below that location.

Occupant Training

The Port Authority has a risk management group which coordinates the fire and safety activities for the various properties under the control of the Authority. Two Port Authority employees are specifically responsible for the fire safety activities in the World Trade Center. Among their responsibilities, the employees coordinate activities with the Center's fire brigade, train fire safety directors, assist in the fire safety training for tenant fire wardens, and coordinate fire drill activities twice each year.

The Center Fire Brigade is made up of Port Authority police trained in fire safety (the officers are primarily trained by The Port Authority of New York and New Jersey; however, they have received some training at the Civilian and Security National Fire Safety Academy on Long Island and at the Nassau County Fire Service Training Academy). Under normal

fire conditions, the World Trade Center police desk would notify members of the fire brigade by radio, and these people would report to the nearest fire cart. The fire brigade would then take the cart to the floor below the reported fire and establish their operation from that location.

The Center has 25 trained fire safety directors to assist in the coordination of fire safety activities throughout the center. In addition to the training provided by the Port Authority, these people also attend training classes at schools that have been approved by the New York City Fire Department for instruction of high-rise building fire safety directors. Each tenant must also provide at least one fire warden to coordinate evacuation activities, and in cases where a tenant occupies large areas on a floor and/or more than one floor, the tenant must provide a fire warden for every 7500 square feet that it occupies on each floor. The fire safety directors train the fire wardens in regard to means of communicating emergency information and instructions, proper evacuation procedures, and their responsibilities for coordinating and providing guidance during evacuations in their respective areas. All tenants participate in fire drills at least twice each year, and these drills are observed and documented by the Port Authority fire safety coordinators at the center.

Weather Conditions

A light snow was falling in Manhattan when the explosion occurred. The wind was from the east at about 10 mph. The high temperature for the day was 29°F, and the temperatures dropped to a low of 21°F.

III. THE EXPLOSION AND FIRE

Discovery and Occupant Activities

At 12:18 p.m. on Friday, February 26, 1993, the normal lunch time activities in Manhattan were disrupted by a massive explosion that occurred in the public parking garage below the World Trade Center. Occupants throughout the complex reported hearing the explosion and feeling the building "shake." For example, an engineer with the Port Authority fire protection group stated that he was on the 44th floor of Tower 1 when he heard and felt the explosion. He estimated that dense black smoke reached his location only a few minutes later. Occupants of buildings in adjacent blocks also heard the loud explosion which rattled windows in their buildings.

Fire Department Notification and Response

The New York City Fire Department received a box alarm at 12:18 p.m. and immediately dispatched a normal assignment consisting of 2 engines, 2 trucks, and a battalion chief. Engine 10 (E-10) and Ladder 10 (L-10) were the first to arrive on the scene because their fire station was across the street from the complex. When the units arrived at 12:19 p.m., they found heavy smoke coming out of the below-grade parking garage entrance on the west side of the building, and occupants of the center already starting to evacuate. Recognizing that there was likely a significant fire in the underground garage area of the complex, the E-10 officer immediately transmitted a 10-75 to the dispatch center,⁵ and another engine was dispatched. On-scene fire fighters entered the smoky garage entrance as quickly as possible in an attempt to locate the fire.

⁵ 10-75 Notification of a Fire or Emergency

A notification signal transmitted when, in the judgment of the officer in command, conditions indicate a fire or emergency that requires a total response of the following units:
3 engine companies, 2 ladder companies, 2 battalion chiefs.

The first alarm battalion chief arrived at 12:23 p.m. and observed the heavy smoke condition at the west-side entrance to the garage. At 12:24 p.m., he transmitted a 10-76 signal, which indicates a fire in a high-rise building.⁶ Upon learning that smoke was also entering the Vista Hotel, he transmitted a second alarm at 12:27 p.m. This officer also received information indicating that smoke was entering Tower 1, so he called for a third alarm at 12:30 p.m.

The first division deputy chief responded to the 10-75 call and arrived on the scene at 12:36 p.m. Upon his arrival, he was notified by the Port Authority that an explosion disrupted all fire protection systems and power to the World Trade Center complex. The incident commander also informed the deputy chief that there was heavy fire on the B2 level, that major structural damage had occurred in the below-grade areas, and that smoke was entering the upper areas of the Vista Hotel and Tower 1. After assuming command, the deputy chief transmitted a 4th alarm at 12:37 p.m.

The Manhattan South Fire Commander responded because he realized that a large incident was developing. The first division deputy chief reported that a fire attack strategy had been established and was being implemented. The strategy included locating the fire, confining it, and extinguishing it. When the Manhattan South Fire Commander assumed command of the incident, he maintained the established fire attack strategy.

Meanwhile, numerous reports of heavy smoke conditions and trapped occupants in the above-grade levels of the Vista Hotel and in Tower 1 were being relayed to the incident commander by the fire department dispatcher. The incident command staff had also received notification that smoke was spreading into Tower 2. In response to these expanding fire and smoke conditions, the incident commander transmitted several additional alarms in order to bring fire department personnel to assist in the suppression, rescue, and evacuation operations.

⁶ 10-76 Notification of a Fire in a High-Rise Building

A notification signal transmitted when, in the judgment of the officer in command, conditions indicate a fire in a high-rise building requires a total response of the following units: 4 engine companies, 4 ladder companies, 4 battalion chiefs, 1 deputy chief, 1 rescue company, field communications unit, mask service unit, command post company, high-rise unit.

The chief of the New York City Fire Department responded to the scene and assumed command of the incident after being briefed by the previous incident commander. When the chief of the department arrived, smoke conditions on the upper floors of Towers 1 and 2 were still worsening, and the smoke in the 6-story atrium/lobby of Tower 1 was so heavy that it made all of the windows in this area completely black. In addition, occupants were evacuating in masses.

The scope of the operations continued to escalate and even more alarms were transmitted bringing personnel and equipment to the scene. As the commitment of the fire department grew, the fire command structure also continued to expand. A central command post was established to coordinate and monitor fire ground operations. Numerous sectors were established to coordinate the operation, and chief officers were assigned to supervise and control operations within these sectors. Staging areas for incoming units were also established on a street in close proximity to the complex.

Early in their operation, the sector commanders in the below-grade levels realized and informed the incident commander that a massive collapse had taken place on the B2 level of the parking garage, and that the collapse involved several levels forming a large crater in the sub-levels. Despite these conditions, the fire fighters initiated and sustained an aggressive fire attack. Over time, they placed nine hoselines into operation in order to suppress the fire. The first hoseline was connected to a standpipe and fire fighters, reportedly, could not get adequate water to operate the hoseline. They disconnected the hoseline and connected it directly to their fire engine parked on the street. Another hoseline was connected to the standpipe system in Tower 1; one was connected to a standpipe on the Concourse level; three were connected to standpipes in the Vista Hotel; and one was connected to a standpipe on a ramp in the parking garage. The rest were connected to fire engines parked on the street. All of the hoselines were operated at various times during the suppression of the fire.

While the fire suppression operations were in progress, other fire fighters performed search and rescue operations which resulted in numerous rescues in the basement levels of the complex. One of these successful rescues included the removal of an injured fire fighter who had fallen into the crater.

The below-grade fire sector commander reported that the fire was under control at 1:48 p.m.; only minor fires under debris and in automobiles remained after this time. The first of five victims to be removed that day was recovered approximately two hours after the explosion. The sixth and last victim was recovered 16 days after the explosion. This delay was due to the victim being buried in the rubble and to the fire fighters' search activities being thwarted by unstable conditions in the basement levels.

Simultaneously with the below-grade operations, a tremendous effort was being put forth to evacuate all the high-rise buildings in the complex. Based on the initial smoke conditions and the location of the fire, the incident commander believed the occupants of the Vista Hotel appeared to be in the most immediate danger. As a result, the incident commander allocated much of his initial resources to the evacuation of that building. The Vista Hotel security director estimated that occupants were able to evacuate the hotel in approximately 10 to 15 minutes. To ensure that all occupants were safely out of the Vista Hotel, fire fighters searched the entire 22-story, 825-room hotel. They completed their search in approximately one hour.

As the evacuation of the Vista Hotel was being completed, the evacuation of occupants of Tower 1 became a top priority objective while still maintaining fire fighter commitment to fire suppression and to the evacuation of Tower 2. The towers were divided into vertical sub-sectors that encompassed groups of five floors, and sub-sector commanders coordinated the activities in their respective areas. Fire crews were then assigned to these sectors and searches of the floors were performed. Since the elevators were not operational, fire fighters had to climb the stairways in order to reach the areas they were to search. In addition to searching the floors, many fire fighters were involved in assisting occupants down darkened and smokey stairways. Fire fighters also evacuated non-ambulatory occupants including people with cardiac conditions, disabled people, and pregnant women from all levels of the buildings.

A few fire fighters climbed the stairways all the way up to the top of the 110-story tower; an operation that took over two hours to complete. Other emergency personnel were brought to the roof of the towers by helicopter, and they began a downward search of the towers.

As more fire department resources were committed to upper floors in the towers, staging areas for equipment and personnel were established. For example, fire fighters brought resuscitation, fire fighting, and other equipment up to the Port Authority cafeteria on the 43rd floor of Tower 1 where this equipment was stored for use in the operation. A medical triage area was also established on this floor. Fire department and Port Authority medical personnel in this area provided initial treatment to several injured people before they were moved out of the building.

The explosion caused an immediate interruption of service for most of the complex's 240 elevators, and over time all of the elevators stopped operating, trapping hundreds of occupants. Many of the trapped occupants were in elevators that were stopped in shaft areas that had no doors. With the assistance of Port Authority and Otis Elevator personnel, fire fighters had to locate and search all elevators in the complex. This proved to be an extremely difficult and time consuming operation. For example, it took fire fighters approximately 5 hours to locate and safely remove kindergarten students and several adults trapped in an elevator in Tower 2. The search for and evacuation of all occupants of both towers was completed by 11:30 p.m.

Earlier in the incident, fire department officers and Port Authority officials also recognized that the loss of electricity was having an effect on evacuation, search, and rescue activities. They also realized that an extended loss of electrical power could result in the loss of telecommunication systems which were being sustained by batteries. In addition to providing telephone service to one of Manhattan's telephone exchanges, air traffic control

information for three major airports was being transmitted over these telecommunication lines; the loss of telephone service could shut down those airports. Accordingly, emergency forces and Port Authority personnel included restoration of electrical power as a high priority objective. Consolidated Edison was given permission to start restoring power to the complex at approximately 6:00 p.m. The electrical power to most of the complex's service conductors was restored by approximately 9:00 p.m., but the re-energizing of circuits within the complex took many more hours. For example, electrical service to most branch circuits in the two towers was restored by midnight.

Operational Overview

The scale of the fire ground operations is difficult to comprehend. To provide perspective, the fire ground operations have been described by New York City Fire Department officials as being equivalent to several multiple alarm fires occurring simultaneously. That is, five alarms basically were sounded for the Vista Hotel operation, five alarms were sounded for the Tower 1 operation, and four alarms were sounded for the Tower 2 operation. In addition, another alarm was sounded for miscellaneous resources, and these fire companies were used as needed. All of these operations were coordinated through a central fire command group. In total, 16 alarms were sounded during this incident and, at the height of the resource commitment, approximately 45 percent of the on-duty New York City Fire Department personnel and equipment were being used at the fire scene. For a single incident, this was the largest commitment of New York City Fire Department personnel, equipment, and resources in the history of the department.

In addition to the New York City Fire Department commitment, personnel from several agencies, such as the Port Authority Police, New York City Police, and the New York Transit Police, also made commitments of personnel to this incident. Personnel from these organizations assisted the New York City fire fighters during their search, evacuation, and other operations at the complex.

Occupant Activities and Evacuation

Due to the magnitude of the explosion, a large number of people in the complex were immediately aware that something significant had happened. The fire alarm and voice communication systems in the Vista Hotel and in Buildings 6 and 7 remained operational and were used to initiate and to coordinate the evacuation of these buildings. In Towers 1 and 2 and in Buildings 4 and 5, nearly all fire alarm, fire detection, communication, and public address systems routed through the OCC became inoperative when the explosion destroyed conductors and other electrical components for these systems. In addition, heavy smoke forced the OCC operator to leave the center, which was very close to the explosion area. As a result of the communications systems being incapacitated, fire safety directors, fire wardens, and other occupants in buildings serviced by the OCC did not get information about the nature of the emergency, and occupants were forced to respond to the emergency without the centralized guidance of the OCC personnel as the complex's fire emergency plan had anticipated.

Without centralized guidance for their actions, many occupants chose to evacuate early in this fire. This resulted in an unorganized, simultaneous evacuation of several high-rise buildings. Though no average evacuation time has been established, evacuation times for occupants in the top floors of the towers have been estimated as being between 1-1/2 and 3 hours.

Other occupants, however, did not immediately evacuate. Many were able to use telephones to call the New York Fire Department and report the explosion. As time passed, occupants continued to use telephones to call the fire department to report that they were trapped within the complex and to report other information. During these later conversations, New York Fire Department dispatch personnel attempted to provide trapped occupants with information regarding the fire, attempted to ensure that the occupants were safe at their current location, and, typically, instructed the occupants to remain calm and to stay where they were until fire fighters could reach them.

Reportedly, a few trapped occupants followed the instructions of news broadcasters who advised people still in the building to break out windows. Though the impact that the broken windows had on smoke spread is not determinable, it was clear that the breakage of windows had an impact on the fire ground operations. Falling debris struck and injured some survivors who were exiting the building on the ground level, and it created additional hazards for emergency personnel who were working in close proximity to the exterior of the building.

Casualties

Six building occupants died as a result of injuries sustained during the explosion. Four of the victims were Port Authority employees, and these four victims were inside Tower 1 in a break room on the B2 level. The break room was separated from the explosion area by a concrete block wall which was destroyed by the blast. The fifth victim was a visitor who was going to his car in the parking garage when the explosion occurred. The sixth victim worked at the "Windows of the World Restaurant" and was last seen in the food commissary on the B1 level shortly before the explosion. Investigators were initially unable to find this victim in the debris in the explosion crater. Once the area was stabilized, investigators continued their search for the missing man and he was finally found on Thursday, March 16, 1993.

One thousand and forty-two people, including 15 people who had blast-related traumatic injuries, were injured. Approximately one-half of the injured people were treated on the scene by emergency medical personnel and released. The other injured survivors were transported to one of five hospitals. Most of these people were also released. The most predominant types of injuries were smoke inhalation and exhaustion. However, several people were cut by broken glass and by other means. Approximately 30 pregnant women were rescued and evaluated by medical personnel, and 20 people were treated for cardiac discomfort. Reportedly, 88 fire fighters (one of whom required hospitalization), 35 police officers, and one emergency medical service member sustained reportable injuries.

Damage

The explosion resulted in a large crater involving six levels of the complex. (See Figure 8.) The top-most point of the crater was a 10-ft by 10-ft section of the Plaza floor slab which was cracked and deflected upward. On the next level down, the Concourse level, a plaster-on-metal-lath ceiling collapsed in the Vista Hotel function room, and directly below the collapse, there was an approximately 18-ft by 22-ft hole in the floor slab caused by the explosion below. On the B1 level there was an approximately 50-ft by 80-ft hole where the floor slab had also collapsed. The largest floor slab collapse occurred on the B2 level. On this level, the collapse area was approximately 130 ft by 130 ft. (See Figure 9.) There were no floor slabs at the B3 and B4 levels directly below the explosion area. As a result, debris from the explosion area and the collapsing floor slabs dropped down to the B5 level, where this material landed on the large refrigeration equipment.

The explosion damage also extended to areas well beyond the immediate crater. Concrete block walls on the B1 level were damaged to the point that they needed to be replaced. The damaged walls included numerous nonbearing walls enclosing rooms adjacent to the area of the explosion, and some of the walls formed a vehicle exhaust plenum along the perimeter of that level. (See Figure 10.)

Similarly, on the B2 level, many nonbearing walls were damaged or collapsed. (See Figure 11.) The damaged walls included the walls forming the vehicle exhaust plenum along the perimeter of that level, and nonbearing walls enclosing rooms, stairways, and the space above the PATH station were heavily damaged. In addition, the enclosure walls for more than 11 elevator shafts were heavily damaged or collapsed completely. Four of these heavily damaged elevator shafts were for Tower 1 express cars that went to the 44th floor; seven of the shafts were for elevators in the Vista Hotel, and most of these elevators traversed the full height of the building. In addition to the heavily damaged enclosure walls, several enclosure walls for elevator shafts scattered throughout the parking garage sustained a lesser degree of damage, i.e., cracks and/or deflection. These elevators serviced the basement levels terminating at the Concourse level. The damaged walls on the B2 level were located below Towers 1 and 2, the Vista Hotel, and the Customs House, and were up to 550 feet away from the blast area.

In addition to the damage to concrete block walls, many metal doors were bent and distorted, and some doors were blown out of their frames by the explosion forces. For example, on the B2 level the elevator doors for a service elevator (Car 50) which had openings on all floors of Tower 1 was blown out of its frame and fell into the elevator shaft. Similarly, in Tower 2 (B2 level) the access door to the service pit of two express elevators (Cars 22 and 23) servicing the 78th floor was blown into the elevator shaft. Other damaged doors included doors enclosing stairways and doors providing access to the exhaust plenum along the basement's perimeter walls. Some of the damaged doors were located in areas where little or no wall damage had occurred, such as the areas on the B1 level below the Customs House.

On the B3, 4 and 5 levels, the damage to concrete block walls was virtually limited to the walls enclosing the mechanical room below the explosion area. Some of the collapsed walls enclosed the ceiling area for the B5 level PATH station. When these walls collapsed, the forces from the explosion and debris caused the plaster ceiling for the PATH station's passenger area to collapse. The explosion forces even cracked tunnel walls for the PATH tracks on the B6 level.

An estimated 200 cars parked in areas adjacent to the explosion crater were heavily damaged. The damage to cars closest to the explosion included their being rolled over, ripped apart and/or dented on all surfaces, and many of these cars burned. Cars more than 100 feet from the edge of the crater were also dented but to a lesser degree.

Similar to the damage to the cars, the most severe flame damage occurred within the crater and in areas immediately adjacent to the crater. The Vista Hotel function room directly above the explosion area was the only area on the Concourse level that sustained heavy flame and heat damage. In these areas, carbon deposits were burned off the wall, ceiling, and other surfaces, and combustible materials were completely consumed by the fire.

Of the seven high-rise buildings in this complex, Tower 1 and the Vista Hotel had the heaviest smoke damage. Tower 1 had light soot deposits in occupant areas up through and including the 110th floor. Heavy soot stains occurred in elevator and stairway doors and frames and on corridor rugs directly adjacent to stairways and elevators. In addition, large deposits of soot accumulated in the freight elevator lobbies on many of the upper floors of Tower 1. Reportedly, smoke stains and soot deposits were evident in all areas of all floors of the Vista Hotel.

Smoke also spread to and filled both Tower 2 and the Customs House; however, it appears that the smoke condition in these buildings was less severe than it was in Tower 1 and the Vista Hotel. The pattern of smoke staining and soot deposit accumulation in Tower 2 was similar to, though not as heavy as, the stains that were observed in Tower 1. Occupants of the Customs House reported that a smoky haze was observable on all eight floors of this building and that this was severe enough in the top three floors that even high security areas, not normally left unattended, were evacuated.

There was no apparent explosion, fire, or smoke damage in Buildings 4, 5, and 7.

IV. ANALYSIS

Cause and Origin

More than 100 investigators from the New York City Police Department Bomb Squad, the Federal Bureau of Investigations (FBI), the Bureau of Alcohol, Tobacco and Firearms (ATF), the New York City Fire Department Bureau of Fire Investigation (FDNY), and the United States Secret Service were involved in investigating the explosion at the World Trade Center complex. This task force of investigators determined that the explosion and subsequent fires were caused by the detonation of at least 1000 lbs. of explosive materials stored in a van that was parked in an area adjacent to Tower 1 and under the Vista Hotel. More specific information regarding the explosion scenario was not available due to the pending criminal litigation.

Explosion and Fire Growth

An explosion is defined as a rapid release of high-pressure gas into the environment. The primary key word is "rapid"; the release must be sufficiently fast so that energy contained in the high-pressure gas is dissipated in a shock wave. The second key term is "high pressure," which signifies that, at the instant of release, the gas pressure is above the pressure of the surroundings.

The released high-pressure gas comes to equilibrium with the surroundings, creating certain effects while doing so. The characteristics of the effects of the gas on the surroundings depend upon: (1) the rate of release, (2) the pressure at release, (3) the quantity of gas released, (4) directional factors governing the release, (5) mechanical effects coincident with release, and (6) the temperature of the released gas. The latter two considerations are relatively straightforward in basic concepts. The striking of surrounding elements by high-temperature gases can cause severe heat damage, including direct damage to surfaces, thermal distortion, and fires in combustibles. Projectiles launched in the release process can impinge and cause crushing, piercing, and/or other structural failures.⁷

⁷ Cruice, William J., "Explosions", Section 1/Chapter 5, *NFPA Fire Protection Handbook*, 17th ed., Quincy, MA., 1991.

The explosion at the World Trade Center was similar to that just described. Upon detonation, the explosive materials produced an immense amount of high temperature gases, smoke, and a shock wave that propagated at supersonic speeds. As the shock wave traveled through the basement levels, it damaged the concrete floor slabs in close proximity to the area of origin, many concrete block walls on most basement levels, and more than a dozen fire doors. The shock wave also ruptured fuel tanks on some cars parked in the garage and rolled other cars over, allowing flammable and combustible liquids to leak. The spilled liquid fuels and solid fuels were then exposed to the developing fire caused by the explosion.

In addition to igniting spilled gasoline, the extreme temperatures and pressures caused by the explosion increased the burning rate of the gasoline and other ignited materials beyond that which is normally associated with these materials. This initial intense burning produced large quantities of combustion products that quickly spread to other areas.

The initial intense fire, in turn, ignited other flammable and combustible automobile components, such as leaking gasoline, tires, and plastic materials, that were not already involved. The fire also ignited miscellaneous combustibles, such as insulation on electrical wires and telephone cables, within the basement area. Ultimately, about 25 - 30 cars burned and, in many instances, all the flammable and combustible materials in the cars were completely consumed, indicating that many of the cars burned for a prolonged period of time.

Unlike the initial accelerated burning associated with the explosion, subsequent burning likely proceeded at rates slower than would be expected. Many of the parked cars and other fuels ignited by the explosion were within the areas where the floors collapsed; as a result, these burning materials fell into the crater, separating fuel packages. Other cars and combustible materials ignited during the explosion remained on the slightly damaged and intact floor slabs surrounding the collapsed floor slabs. These cars and combustible materials were scattered throughout the peripheral areas, forming separated fuel packages for numerous independent fires. It is recognized that radiative feedback between independent fires within close proximity of each other can increase burning rates. Since many of the scattered fuel packages were at significant distances from each other, radiative feedback was

minimal, resulting in little or no enhancement of burning. Further, explosive forces severely crushed vehicles, altering the physical arrangement of the remaining combustible components, and many of the available fuels were partially buried by debris, further reducing burning efficiency.

The simultaneous burning of 25 - 30 cars and miscellaneous combustible materials created an extremely serious fire, exposing tens of thousands of people to life threatening conditions. However, changing several factors could have readily made conditions even worse. For example, the New York Fire Department was able to initiate and maintain an aggressive fire attack while simultaneously supporting the immense evacuation operations. Their suppression activities, in conjunction with damaged yet operating sprinkler systems, extinguished the fires in about two hours, stopping the production of smoke that was spreading to and affecting occupants in the complex's high-rise buildings. The ignition of more cars, the consolidation of scattered fuel packages, and the involvement of more combustible materials in the building are just a few factors that might have escalated the fire's severity, increasing the difficulty of extinguishment and suppression time. Consequently, these factors would have led to an increased production of smoke being sustained for longer periods of time and leading to a much different and more tragic outcome.

Smoke Movement

Similar to the fire development, smoke movement was initially affected by forces developed during the explosion. The detonation of the explosive materials produced copious amounts of hot, thick, black smoke. In addition, the detonation forces propelled the smoke into areas well away from the explosion area. Because the immense shock wave severely damaged floor slabs and numerous separation walls in the basement areas, these building components could not prevent the horizontal and vertical movement of smoke to other areas of the complex. The speed with which the propelled smoke moved through the building can be understood by a report from a Port Authority engineer who was on the 44th floor of Tower 1 when the explosion occurred. This engineer reported that smoke reached his location about one minute after the explosion and that visibility in his area was quickly reduced. Even with the aid of a flashlight, he could only see up to one foot away.

The explosive forces influencing the movement of smoke quickly subsided, and natural forces became the primary factors affecting smoke movement. In the immediate area of the fire, forces associated with the fire plumes and the natural buoyancy of the hot gases moved the

smoke. However, as the smoke traveled away from the fire area, another natural force – stack effect – primarily influenced smoke movement.

According to the NFPA's *Fire Protection Handbook*, stack effect is characterized by a strong draft from the ground floor to the roof of a tall building. This phenomenon is like the natural draft up a chimney and is best illustrated by the smoke spread through Tower 1, which was one of the tallest buildings and where extreme amounts of smoke accumulated. The magnitude of stack effect is a function of the building height, the air-tightness of the exterior walls, the air leakage between floors of the building, and the temperature difference between the inside and outside of the building. Two of these factors, i.e., building height and temperature differential, were significant contributors to the stack effect in the complex on the day of the explosion. Leakage between floors, another factor affecting stack effect, occurs through all vertical openings in a building. These openings can be as small as a crack in the floor and wall assemblies; as subtle as an electrical conduit or busway, or as large and obvious as the holes in the floor slabs, elevator shafts, and stairways made by the explosion.

Stack effect forces tended to push smoke into elevator shafts with openings in the lower regions of the buildings. (See Figure 12.) As the smoke moved up the shafts, it eventually began to seep out of the elevator shafts and enter occupied floor levels, even when the elevator doors were closed. The direction of smoke movement, i.e., into or out of elevator shafts, depended on numerous constantly changing variables influencing the stack effect forces. The sky lobbies in the tower provided insight into the complexities of

smoke movement in elevator shafts. In these areas, smoke moved out of some elevator shafts, typically express elevators from floors below the sky lobby, and moved into other elevator shafts, typically local elevators for floors above.

Smoke staining on upper floors confirmed that the damaged elevator shafts were one of the primary paths for vertical smoke movement in Tower 1. For example, the heaviest soot accumulations in Tower 1 occurred near Elevators 1 - 4 (express elevators from the lobby to the 44th floor) and near Elevator 50 (a service elevator with openings on all floors). When the explosion occurred, the shafts and doors for these elevators sustained significant damage on the B2 level, allowing copious amounts of smoke from the initial explosion to quickly enter these elevator shafts.⁸ Similarly, smoke released by subsequent fires also spread into Tower 1 via this avenue.

Moreover, a comparison between sub-level elevator damage and smoke stains revealed that a strong relationship existed between elevator damage and smoke movement in all buildings affected by the spreading smoke. The Vista Hotel sustained the most extensive damage to elevator shafts and experienced some of the most significant smoke infiltration during the incident. Tower 1 had the next most severe damage to elevators and it, too, experienced significant smoke infiltration. Tower 2 had only minor damage to elevator enclosures and the smoke infiltration in this building was less than in Tower 1. Though many walls below the Customs House were damaged, the two basement elevators in his building were not damaged. As a result, the Customs House had the least amount of smoke infiltration compared to the other smoke-charged buildings.

Smoke movement through the elevator shafts with closed doors and intact enclosure walls also contributed to the vertical smoke movement in Tower 1 and was the primary means for smoke travel to the upper floors in Tower 2 and the Customs House. Only two

⁸ Note that, although the elevator cars 1-4 provide occupant access beginning at the lobby, their shafts extend down into the basement area.

elevators in Tower 2 (express elevators to the 78th floor) had notable damage on the B2 level. Nevertheless, smoke stains on many elevator doors and fine soot deposits on most interior surfaces were observed throughout Tower 2.⁹ Smoke-stained elevator doors were observed as high as the 107th floor. Similar to the smoke movement in Tower 2, smoke on the B1 level of the Customs House moved into elevator shafts with closed doors and intact enclosure walls. After moving vertically in the shaft, the smoke again moved through the closed doors, resulting in a reported light, smoky haze on the lower floors and a heavy, smoky haze on the top three floors of the Customs House.

Stairways also contributed to vertical smoke movement in the complex and significantly influenced the mass evacuation. For example, smoke that accumulated in the ground-level lobby area of Tower 1 entered the three exit stairways through doors being held open by evacuees leaving the stairways and by fire fighters entering the stairways. Further, on floors higher in the tower, smoke that had already spread by way of the elevator shafts, etc., began to accumulate on occupant floors, and, as occupants opened stairway doors to evacuate or as they held open the doors to await an opportunity to evacuate, smoke moved into the stairway. Over time, most of the areas in the towers became charged with smoke and the significance of the stairways' and the elevator shafts' contribution lessened as conditions changed during this prolonged event.

As stated earlier, smoke did not spread into Buildings 4, 5, and 7. They apparently remained smoke-free as a result of their location with respect to the explosion. Buildings 4 and 5 were located on the east side of the enclosure walls for the New York Transit Authority subway track, and the explosion was on the west side of the enclosure. (See Figure 10.) Therefore, direct blast forces and smoke had to pass through the two vehicular tunnels under the subway track enclosure in order to reach Buildings 4 and 5. This convoluted path greatly reduced the amount of smoke that spread into the B1 level below Buildings 4 and 5. Building 7's sub-level did not connect to the complex's sub-levels, therefore smoke in the sub-levels could not reach Building 7.

⁹ Smoke passing through the cracks around a closed door will leave smoke stains on the door and frame. These stains can be used to indicate the direction of smoke movement; however, stains alone are not good indicators of total smoke accumulation in a space, optical density, the volume of smoke that may have moved past the door, or the time over which the stains may have accumulated.

Smoke Characteristics

One of the most remarkable outcomes of this tragic event was that there were no smoke-related fatalities. This is radically different from other fires documented by the NFPA, such as the 1980 MGM Grand Hotel fire in which many of the 85 fatalities were evacuees who died from inhalation of toxic smoke in exitways. Like the MGM Grand Hotel fire, occupants of three buildings (i.e., Towers 1 and 2 and the Vista Hotel) of the seven-building complex were exposed to significant amounts of smoke during their evacuation.

Accounts from escaping occupants and fire fighters working in Tower 1 revealed some of the heaviest smoke encountered in their evacuation occurred in the lower part of that tower. Other evacuating occupants reported being exposed to smoke for extended periods in the smoke filled stairways. These reports suggest that some of the escaping occupants endured some of the most severe smoke exposures while traveling through stairways and areas in the lower one-third of the tower.

Reports from survivors also suggest that occupants who did not immediately evacuate, either by choice or circumstance, were exposed to less severe conditions. However, there were a few exceptions. One of the most extreme examples of smoke exposure was the 10 survivors who were found by fire department personnel in an elevator in Tower 1. This elevator was in a shaft that was heavily damaged on the B2 level and large quantities of smoke had moved vertically through its shaft. Though several of the occupants were critically injured, all survived approximately 3-1/2 hours of exposure to the smoke. These perceived details are consistent with the facts that smoke was being generated in the basement of the complex and the fact that the elevator shafts and stairways were the primary paths for vertical smoke movement in the tower. Another example of the extended exposure to smoke was the group of kindergarten students and adults trapped in a Tower 2 elevator. All survived approximately 5 hours of exposure to smoke.

The lack of smoke-related deaths, even though thousands of people were exposed, in many cases for long periods of time, strongly suggests that the concentrations of toxic gases were low by time the smoke reached occupied areas. Information regarding the explosive materials could provide insight into what toxic gas yields were produced during the detonation. In addition, an analysis of the burning rates, types and quantities of fuels, and the availability of oxygen could also provide insight regarding toxic gas production in the fires following the explosion. Lacking such specific information and data, exact toxic levels at any location or at any time cannot be determined. Nonetheless, it is reasonable to expect that lethal levels of toxic gases were being produced and were present in areas close to the fires. The survival of so many people reveals that the concentrations of lethal gases must have been reduced between the areas where the smoke was being generated and the areas where occupants were attempting to travel through the smoke.

Investigators believe that the dilution of the smoke was a major factor contributing to the survival of occupants. Even though the fires and explosion seemingly involved a large area of the complex, the area was, in reality, a very small part of the complex's total area. As a result, large quantities of air were available in the facility and were drawn into the smoke even before it spread out of the sub-levels. More air was entrained as the smoke moved up through the buildings. For example, the collapsed section of floor slabs allowed smoke and fire in the sub-levels to spread vertically into the Vista Hotel function room. Smoke from this area spread to other areas of the Vista Hotel and spread through broken windows into the lobby of Tower 1. (See Figure 13.) Outside air entering the lobby through broken glass panel walls in the mezzanine mixed with the smoke and probably pushed smoke accumulating in the lobby down to the floor where it could enter elevator shafts that had doors in that area.

The smoke continued to entrain large amounts of fresh air from countless sources as it moved higher into all of the buildings. Even though the smoke was diluted, it still

obscured egress paths and caused severe respiratory irritation for many of the escaping occupants. More importantly, the smoke appears to have caused significant concern on the part of many occupants and may have increased the confusion during the evacuation.

In this incident, it is also likely that large amounts of dust and small particulate material were produced when building components were shattered and the environment was disturbed by the detonation. This material would have been forced into the air. The explosion and shock wave probably propelled the dirt and dust through the basement levels, up through voids made in the floor slabs, and up through damaged elevator shafts. In addition, the dirt and dust mixed with the smoke cloud and likely contributed to the initial obscuring effects of the smoke. (The NFPA was unable to obtain results of the soot sample analyses. Therefore, it is not possible to comment further on this aspect of the incident.)

Performance of Primary Electrical Systems

At the time of the incident, one of the complex's eight sets of service conductors that provided power to the complex's PDC had been de-energized for scheduled maintenance. Therefore, prior to the explosion there were seven operating sets of service conductors providing power to the complex. The PDC, in turn, supplied electrical power to the refrigeration plant via seven feeders and these feeders passed through a vertical junction box on the B2 level near the explosion area. (See Figure 11.) The junction box was severely damaged during the explosion and four of the seven feeders with the box were also damaged, causing shorts and/or grounding of the circuits. This damage was detected by the complex's primary circuit protection equipment, which disconnected electrical power to the four damaged feeders. Simultaneously, the short circuits and/or grounding of circuits were detected by the protective relays at the Consolidated Edison substation. As a result, the Consolidated Edison substation's protective devices also opened, disconnecting the four sets of service conductors supplying energy to the complex.

In addition to providing electrical power to the refrigeration feeders, the four sets of service conductors that were disconnected at the Consolidated Edison substation also provided power to electrical substations in Towers 1 and 2; Buildings 4, 5, and 7; the Customs House; the Concourse level; and the basement levels. Therefore, the opening of protective devices at the Consolidated Edison substation resulted in the loss of normal electrical power to most areas in the complex. Almost all local television stations broadcast from the large antenna atop Tower 1. As a result, they, too, lost power and the ability to transmit a signal after the explosion.

As indicated earlier, one circuit for the north side of Tower 1 and west side of Tower 2 was also down for maintenance before the fire occurred. Therefore, the opening of service conductor protective devices for the three remaining circuits interrupted normal electrical power to one half of every floor in both towers. In addition, one of the four sets of service conductors supplying power to the other half of each tower, i.e., the south side of Tower 1 and east side of Tower 2, was interrupted when the protective devices at the Consolidated Edison substation operated. Similar types of power losses were experienced in Buildings 4 and 5, the Customs House, the Concourse level, and the basement levels.

Despite the interruption of normal electrical power to most circuits in the complex, approximately three eighths of the normal electrical circuits still received electrical power after the explosion. The complex's electrical system was able to maintain at least some electrical power to the towers because these areas were vertically divided into two electrical zones with electrical power supplied to the towers by numerous feeders. Similarly, some electrical power was maintained in Buildings 4 and 5 and the Customs House since these buildings were also receiving electrical power from multiple electrical feeders. The Vista Hotel did not lose its normal electrical power during the explosion because electrical power for that building came from a different Consolidated Edison substation, and it had an electrical distribution system that was completely separate from the rest of the complex.

Performance of the Emergency Electrical Systems

In the areas affected by the loss of normal electrical power, HVAC systems and normal lighting systems shut down. The alternate electrical system immediately transferred any available normal electrical power to emergency lighting and other emergency communication systems in tower areas that were affected by power outages and were not damaged by the explosion. In addition, the emergency generators immediately started and provided power to the undamaged circuits for elevator motors, fire pumps, and emergency systems in Buildings 4 and 5, which did not have alternate electrical systems. The emergency generators were also acting as a backup power supply for the normal and alternate electrical systems providing power to emergency circuits.

Some investigators believe that the significant voltage fluctuations that occurred during the explosion may have caused electrical relays to drop out in the control systems for elevators and HVAC equipment. Therefore, many of the elevators and much of the HVAC equipment throughout the complex stopped operating, probably because of the control problems rather than the loss of electrical power to the drive motors.

The emergency generators ran for approximately 20 minutes before an "overheat" condition occurred, causing the diesel engines to automatically shut down. The cooling water system for the engines was damaged during the explosion, and the damaged system could not effectively cool the engines over time. The New York Telephone emergency generator had a similar cooling system as the Port Authority emergency generators. Like the Port Authority emergency generators, the New York Telephone generators stopped operating because of an "overheat" condition. However, telephone service was not interrupted because batteries had been provided to back up the generators.

It appears that some stairway lighting systems in both sides of both towers operated for about 1 hour and 15 minutes because the emergency lighting systems were being powered by the normal or alternate electrical system. Because of a reported concern for the safety of fire fighters working in the blast area, the normal electrical service to the complex was shut down at 1:32 p.m., removing power from the few remaining normal circuits and "alternate" power circuits. This action in conjunction with the loss of emergency generators resulted in the remaining occupants having to evacuate in complete darkness.

Performance of Fire Protection Systems

Critical conductors connecting the OCC with the voice communication, public address, and fire detection systems in Towers 1 and 2, and Buildings 4 and 5 were installed on the underside of the B1/B2 floor/ceiling slab. Similar to the feeders for the refrigeration plant, these conductors ran through a junction box and all conductors inside were damaged during the explosion. (See Figure 11.) As a result of this damage, the systems could not be used at any point in the incident. In addition to inoperative systems, OCC operators were forced out of the center by extreme smoke conditions. Accordingly, the few (if any) emergency systems that may have remained operational were not used.

The loss of the OCC was one of the most significant events since all of the complex's emergency response procedures were based upon the premise that trained OCC operators would be able to receive information from areas involved in the emergency. In turn, the OCC operators would be able to provide emergency response instructions to trained people throughout the complex. In addition, the OCC operators could provide information directly to the building occupants using the public address system if necessary. Without the ability to communicate with OCC, the trained personnel throughout the complex could not coordinate their response, and the general population was forced to determine their own courses of action.

In many instances, occupants may have been exposed to less threatening conditions by remaining in place. However, without the guidance from a coordinated emergency response and without information upon which to make decisions, many occupants chose to evacuate. As a result, they moved through the smoke-filled exit stairways, placing themselves in danger for long periods of time.

The looped water main supplying the standpipe systems for Towers 1 and 2, Buildings 4 and 5, the Customs House, the Concourse level, and the basement levels was damaged by the explosion. Even though the system was damaged, fire fighters were able to successfully connect several hoselines to the standpipe system, and these hoselines were

used for fire suppression in the area of the explosion. It appears that the multiple water supplies, i.e., connection to the New York City municipal water system, gravity tanks, and fire department connections, allowed most standpipe systems to remain operational. Reportedly, Port Authority personnel were able to isolate the damaged areas early in the fire suppression activities, minimizing the loss of water through damaged piping.

Like the standpipe system loop main, the loop main providing water to the sprinkler systems protecting Buildings 4 and 5, the Customs House, the Concourse level, and all the basement levels was damaged during the explosion. This temporarily impaired the ability of all sprinkler systems to protect their respective areas. This impairment continued until Port Authority personnel were able to isolate the damaged portions of the loop main. Once the damaged areas were isolated, the sprinkler system operation was supported by the pressurized water in the New York City municipal water system, fire department connections, and the electric fire pumps when they were restored to service.

The sprinkler systems in the basement areas near the explosion sustained substantial damage and became useless against the subsequent fires. However, some sprinklers around the perimeter of the explosion area operated. Due to the extensive amount of explosion damage to cars and equipment in the garage, it was not possible to assess the effectiveness of the operating sprinklers in the peripheral areas.

Since the fire did not extend into the towers, none of the sprinkler systems in the towers operated, although their operational capability was maintained because they were supplied by gravity tanks that were not impacted by the explosion. Since the loss of electrical power and emergency power would have stopped the operation pumps for the domestic water supply, the gravity tanks could not have been automatically reserviced. As a result, the tower sprinkler systems would have remained effective only until all the water in the gravity tanks was used. Fire department personnel still could have supported the system by pumping into fire department connections, and normal sprinkler service was renewed when domestic water pumps were placed back into service approximately one day after the explosion.

Code Analysis

In the interest of comparing conditions and other details regarding this incident with current national consensus codes, the 1991 edition of the *Life Safety Code*[®], (LSC) and the 1993 edition of the *BOCA National Building Code*[™] (NBC) were used. It was recognized, however, that these codes were not part of the legal requirements governing life safety at the World Trade Center. The following discussion concerns requirements that have particular relevance to this fire. It is not intended to be a complete description of all parts of the codes that could be applied.

The LSC recognizes that high-rise buildings can pose several problems during fire emergencies. These problems include, but are not limited to:

- potential for significant stack effect
- difficulty in evacuation
- difficulty experienced by fire services in reaching the fire.

Accordingly, the LSC contains requirements intended to minimize fire risks to occupants of high-rise buildings. The LSC also recognizes that the characteristics and training of occupants can affect their ability to perform in a fire emergency.

Chapters 26 and 27 of the LSC provide requirements for "New Business Occupancies," and "Existing Business Occupancies," respectively. Many of the LSC requirements relate directly to exit design, and these requirements provide the criteria for the number of exits (i.e., a minimum of two), means of egress components, arrangement of the means of egress (i. e., common paths of travel, etc.), travel distances, exits discharge, emergency lighting, etc. These issues are also addressed in Chapter 10, *Means of Egress*, of the 1993 BOCA/NBC. The three enclosed stairways serving as the means of egress in each of the two World Trade Center Towers is consistent with the intent of the LSC and BOCA/NBC exit design.

[®] Registered Trademark, National Fire Protection Association.

[™] *Basic/National Building Code*, Building Officials and Code Administrators International, Inc., Country Club Hills, Illinois.

In addition to requiring fire protection and other emergency equipment, the LSC in Chapter 31, Operating Features, requires that the occupants of business buildings subject to occupancy by more than 500 people or more than 100 people above or below street level will be trained with respect to exiting during fire emergencies. NFPA 1, *Fire Prevention Code*, 1992 edition, has a similar requirement. Chapter 7 of the 1993 BOCA *Fire Prevention Code* provides requirements for emergency planning and preparedness. The semi-annual fire exit drills required for all tenants and supervised by Port Authority officials were consistent with the NFPA and BOCA requirements. Reportedly, fire exit procedures anticipated that instructions regarding the exact course of action for the evacuees would be provided by the two-way communication system and/or the public address system. In this incident, all communications were incapacitated early in the incident and, as a result, evacuees had to make decisions regarding their course of action based only upon cues that they were receiving at their respective locations.

The fire evacuation plan for this complex anticipated that the egress paths would be lighted during an evacuation. As stated earlier, lights remained operational for approximately 1-1/4 hours in the exit stairways until all electrical power in the complex was shut off. All areas, including the exit stairways, then fell into darkness. The darkness in the stairways no doubt increased the anxiety for the evacuees.

Recognizing the importance of maintaining reliable emergency electrical power supplies, the NFPA promulgates a standard that covers the performance requirements for power systems providing an alternative source of electrical power to loads in buildings and facilities in the event that the normal power source fails. This standard, NFPA 110, *Standard for Emergency and Standby Power Systems*, was adopted as a standard by the

NFPA in 1984 and published in 1985, approximately 15 years after the World Trade Center was constructed. The 1993 BOCA/NBC also contains requirements addressing emergency electrical systems and standby power systems in Sections 2706 and 2707, respectively. This document references NFPA 70, *National Electrical Code*®, which in turn refers to NFPA 110 for additional information regarding the performance of emergency and standby power systems.

The current, 1993 edition of NFPA 110, allows city water to be used for filling or make-up water of emergency power supply systems that use water as part of the cooling mechanism. However, the document does not allow utility, city, or other water sources to be used for the cooling systems of emergency power supply systems requiring intermittent or continuous water flow, pressure or both. It is the intent of the standard to require a cooling system that is self-contained and cannot be interrupted by events outside of the facility. A cooling system according to this design would have increased the potential for emergency generators to remain operational at the World Trade Center, and these generators would have been available to supply power to the emergency lighting and other emergency systems that were not damaged by the explosion.

Post-Incident Fire Protection at the World Trade Center

After the explosion, the Port Authority was immediately concerned with the safety of all people working in the complex during the incident recovery. As soon as possible, an evaluation of the complex's fire protection systems was performed, and a plan was prepared regarding the restoration of critical fire protection and life safety systems. For several days after the explosion and fire, access to areas in the towers and other areas of the complex was restricted because the fire protection and life safety systems were not operational. As the systems were restored, access restrictions were eliminated.

In addition to being concerned with restoration of systems, Port Authority officials developed a plan to enhance the complex's existing fire protection and other emergency systems. The enhancement project included the following improvements to programs and equipment:

1. Uniformed and Trained Fire Safety Directors -- These people will be stationed at a main fire control desk located in the lobby of each tower. The main fire control desk will be staffed 24 hours a day. Provisions are to be made to transfer the operation of one control desk to another if there is cause to evacuate the control desk.

The deputy fire safety directors' desks will be equipped with TV monitors, wireless communications station, standard telephones, and an emergency equipment kit containing the following: flashlights, filter masks, essential keys, 2-way radio, and bull horn megaphones.

In addition, wardens will be stationed at fire control desks in each sky lobby from 7:00 a.m. to 7:00 p.m. The deputy fire safety directors will be required to have successfully completed the New York City Fire Department certified fire safety director training program.

2. Vertical Security Patrols -- Personnel, other than the deputy fire safety directors, will maintain a constant patrol of the stairwells from 7:00 a.m. to 7:00 p.m. The guard will be an extension of the sky lobby deputy fire safety director, and will check for obstruction and other safety hazards in the stairways. The guard will also periodically pass through tenant floor corridors increasing visibility of Port Authority staff and checking that re-entry doors are not locked. The guard will have direct radio communication with the sky lobby deputy fire safety director.
3. FM Wireless Communications System -- This system will provide backup communications in the event that the primary or fire alarm intercom systems are rendered inoperative. While this system was being installed, interim cellular telephones were issued to each floor warden. These telephones were provided with emergency numbers including 911.
4. Alternate Primary Power -- A backup source for primary power to the complex will be implemented reducing the potential for a loss of the primary electrical power. This backup primary power source will be from a completely separate power grid.
5. Trailer Mounted, Air-Cooled, Emergency Generators -- These generators will provide a backup to the existing emergency generators in the complex and will remain in place until the alternate primary power system is operational.

6. Battery Pack Lights for Elevators and Stairways -- This equipment will serve as a backup to the current emergency lighting systems which are powered by the normal electrical system, the alternate electrical system, and the emergency generators.
7. Phosphorescent Signs -- These signs will serve as a backup in the event that all emergency lighting systems fail. The signs will be mounted in exits in order to identify re-entry points and the main floor and mezzanine exits from stairways. Signs will also be installed in elevators in order to identify the car number and location of the emergency intercom.
8. New York City Approved Class E Fire Alarm and Communication System -- Six new fire alarm/communication systems were installed. The systems will service Towers 1 and 2, Buildings 4 and 5, basement levels, and the Concourse level. All systems have decentralized and separate control centers located in the lobby of the high-rise building, and these desks will be staffed 24 hours each day. The control centers for the basement and Concourse level systems will be in a safe area. Though all six systems will have separate detection capabilities, each system will be able to provide voice communications and strobe light activation for all systems in the complex.

In addition to a primary control center in the lobby, both towers will have secondary control centers located on each sky lobby floor and redundant electronics providing communications between the primary and secondary control centers.

V. DISCUSSION

At the time of this incident, the World Trade Center's fire protection and life safety systems were considered to be near state-of-the-art, capable of providing occupants with an adequate level of protection. However, many of these systems failed to perform or their performance would have been questionable had the fire spread beyond the initial materials involved.

The World Trade Center bombing and resulting fire is the latest incident to expose the potential danger of high-rises. Because of their extraordinary heights, high-rise buildings present a unique fire protection challenge to designers and pose distinct fire suppression concerns to fire officials. Analysis indicates that severe high-rise building fires can include rapid fire growth and development and extensive smoke spread, which can threaten occupants in areas remote from the fire. In addition, the time required for fire fighters to establish effective fire fighting operations can be extensive simply because of the vertical arrangement of the structure. These concerns are especially true in large, tall, densely populated structures such as the World Trade Center complex where emergency evacuation is difficult or impractical. Such "mega-high-rises"¹⁰ and other occupancies may warrant additional reliability of fire protection systems because of these life safety considerations. Prior to the incident, there was no attempt by code officials to treat "mega-high-rises" such as the World Trade Center differently from other high-rise buildings regarding the reliability of fire protection system design. However, since a "single event" in such mega-high-rises can simultaneously expose tens of thousands of people to dangerous conditions, more reliable performance of fire protection components may be appropriate. Further, the World Trade Center complex contained private enterprises and government agencies that, had their operation not been maintained, could have impacted on the world commodities market, for example. This additional variable may have further warranted additional considerations of fire protection features and reliability.

¹⁰ A definition that might capture the potential hazards associated with mega-high-rise buildings and which could be tracked for fire analysis purposes would be: A mega-high-rise is a large, tall (greater than 50 stories), densely populated structure where emergency evacuation is difficult or impractical. They are further characterized in that the ordinary fuels which they contain may result in rapid fire growth, development, and spread because of their geometric arrangement, and in extensive smoke spread throughout the structure which threatens occupants in remote areas from the fire origin. Further, the time required for fire fighters to establish effective fire fighting operations can be extensive because of the vertical arrangement of the structure.

There were some examples of fire protection redundancy in this event that illustrate the potential for further effectiveness. Following the explosion, many areas in the towers had primary power because of the multiple electrical feeders and other areas were effectively powered for a time by the emergency system. The Vista Hotel had emergency power during the entire incident because the emergency generators for the hotel were separate from those for the complex. Similarly, normal telephone service was maintained throughout the incident because emergency generators for telephones were backed up by an emergency power supply using batteries. In light of the success of the redundant and alternate systems, many of the planned Port Authority enhancements for the World Trade Center complex include the introduction of redundant and/or alternate emergency systems for the systems that failed to operate satisfactorily.

Although fire protection designers normally would include a "single event" scenario in their performance criteria of fire protection systems, until this event, most fire protection design philosophies for such building complexes would not likely have included "single event" scenarios such as terrorist acts. This "single event" at the World Trade Center complex has initiated an active discussion among fire protection professionals as to what, exactly, a "single event" scenario should include. In light of this incident, fire protection designers and code officials should consider broadening their responsibilities to include security issues or other such subtle changes in our society in achieving dependable and reliable fire protection system performance for such critical occupancies.

Further, most high-rise buildings are not designed to be totally evacuated in an emergency. "Defend-in-place" is a concept that designates evacuation of only those floors immediately at risk from fire, with other occupants remaining protected by fire barriers, fire doors, suppression equipment, etc., while they await further instruction. However, this concept is

dependent upon a communication system that allows information about the fire and impending danger to be effectively disseminated to all building occupants and that the integrity of the fire protection design is sustained. Neither of these criteria was achieved in this incident.

In spite of some positive aspects of emergency and fire protection system performance, the massive and severe explosion impacted virtually every fire protection feature in the complex. The public address system, the fire alarm voice communications systems, and the smoke detection systems were all immediately made inoperable by the explosion. Shortly after starting, the emergency generator engines overheated and shut down because components of their cooling system were damaged by the explosion. Further, once ignition of combustibles occurred, natural air movements quickly distributed products of combustion to occupied areas through horizontal and vertical openings, and soon total evacuation of the complex was necessary. Many occupants entering stairways began to be confronted by the smoke. Then, due to the electrical power failure, the occupants experienced total darkness in the stairways and resorted to other means of illuminating their exit paths. The unexpected mass evacuation further impacted adequate performance of the exiting system since the stairways soon filled with people who were waiting for an opportunity to enter stairways and held open doors, thus allowing smoke to migrate from the floors into the stairways. Fortunately, because the spread of the fire was limited and the smoke was diluted, none of the occupants died from smoke exposure.

The facts of the World Trade Center incident and the lessons learned from the fire can serve as an impetus for the fire safety community to re-examine the current design philosophies and future directions for high-rise fire technology. Fire protection professionals need to ask themselves if fire safety provisions should be different for common high-rises as compared to mega-high-rises and, if so, what should those differences be? The fire protection community should also re-examine the roles of redundant systems, separation criteria for vital equipment, systems maintenance, code enforcement, and other relevant issues. Re-examination is critically important if we are to be prepared to deal with tomorrow's fires.

The World Trade Center fire is a potential window onto the future of fire protection technology and should serve as a learning experience. Even though the terrorist aspect of this incident distinguishes it from other major fires, the resulting smoke spread due to "stack effect" is not unusual in high-rise structures and should be carefully studied as one of the most important elements in evaluating the performance of fundamental fire safety concepts. Additionally, the actions of occupants lacking emergency instructions can provide useful insight into the behavior of high-rise occupants. In this incident, many occupants chose to evacuate, placing themselves in danger for longer periods of time than necessary. Fire safety training for individual occupants regarding fundamental fire survival techniques could have been of great assistance.

Occupants of high-rise structures rely on building, fire, and other officials to provide adequate levels of fire protection. While every person must take a certain amount of responsibility for his/her own safety, the public has a right to expect that the buildings in which they live and work contain reasonable provisions to protect them. As a minimum, building designs and fire protection systems must be equivalent to the level of protection specified by national consensus fire codes and standards. The growing inventory of high-rise buildings in this country should be reviewed to ensure that minimum levels of fire protection are present. In addition, public officials must ensure that building plan reviews and inspection processes have been established to guarantee that appropriate codes are followed, and determine whether adoption of new codes or updating of existing codes is needed. Periodic follow-up inspections of buildings are also necessary to ensure that the levels of fire protection are maintained throughout the life of the building.

Recent fatal high-rise building fires have demonstrated the importance of inspection and maintenance of fire protection systems. One of the more recent high-rise fires resulted in three fire fighters losing their lives, further underscoring the importance of minimum fire safety requirements for these buildings. Finally, owners, insurers, security, fire protection

professionals, and code developers may want to re-examine fire protection designs in high-rise structures, especially where those structures accommodate large numbers of people (such as in mega-high-rises) or where the political and economic impact is great, to ensure that the protection systems achieve a high degree of reliability during a "single event" occurrence. The NFPA's *Life Safety Code*[®] addresses occupant safety in both new and existing buildings; an important consideration in fundamental fire safety principles in the built environment.

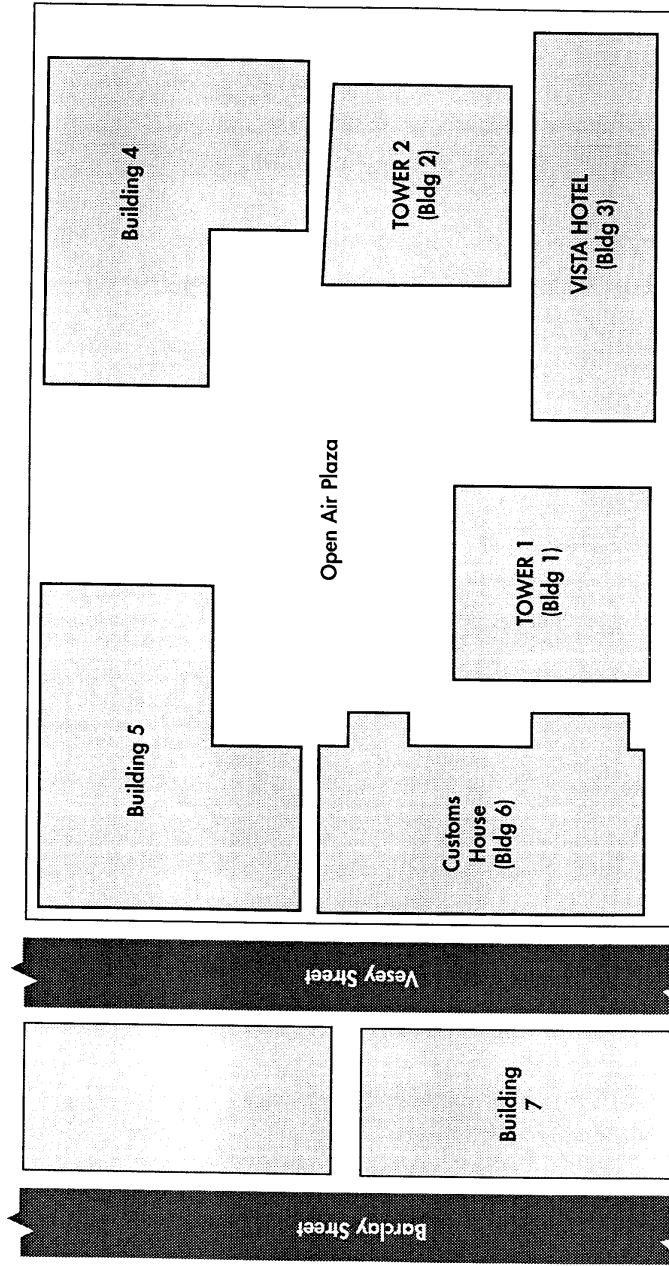

**WORLD TRADE CENTER COMPLEX
Simplified Plan - Figure 1**



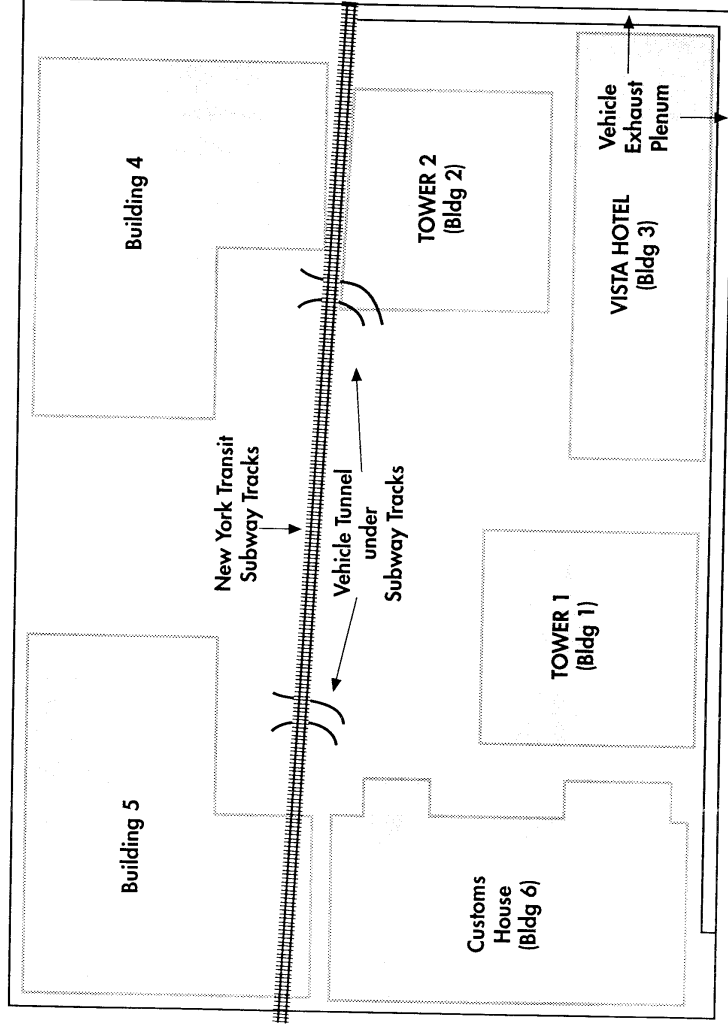

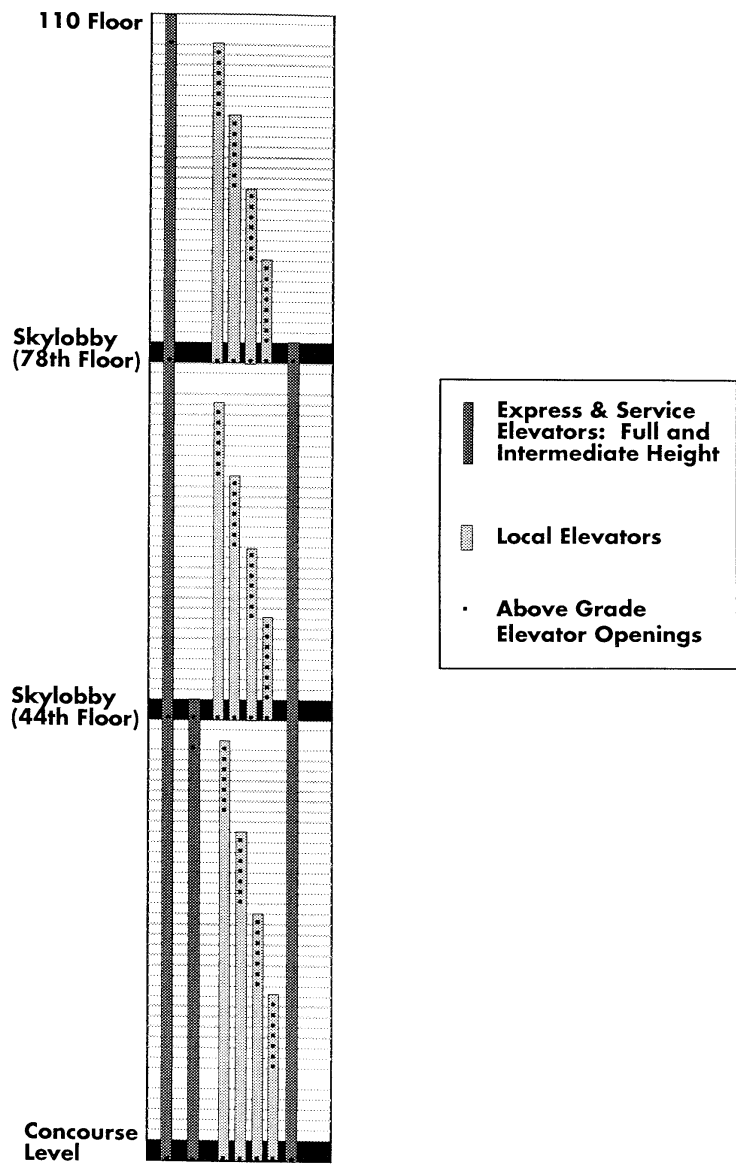

**WORLD TRADE CENTER COMPLEX
B-1 Level Simplified Plan - Figure 2**

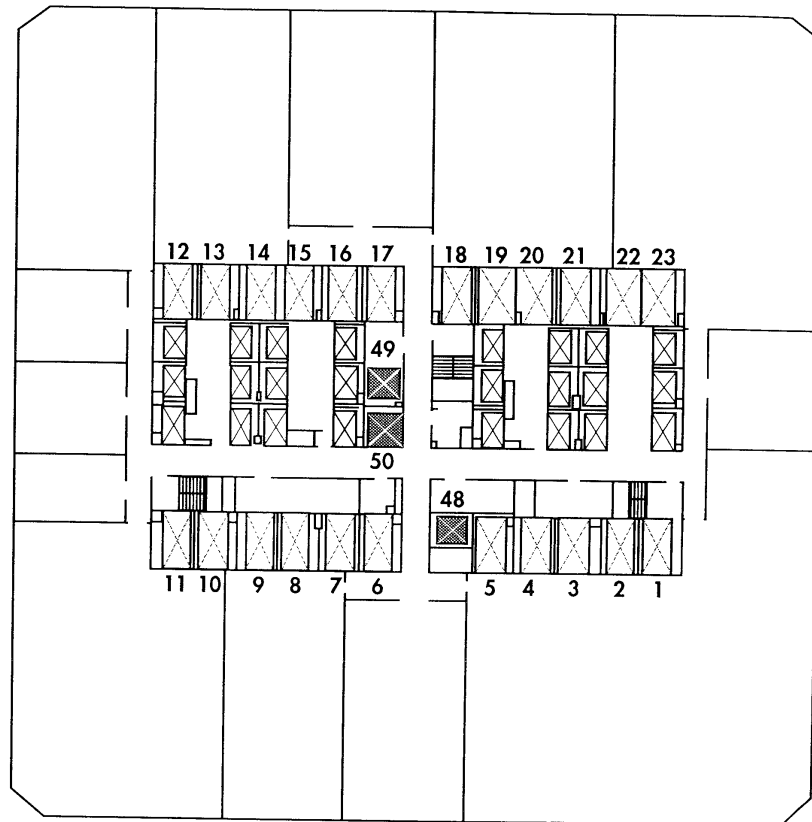

TOWER ELEVATORS
Figure 3



Passenger Local Elevators 

Passenger Express Elevators 

Freight Elevators 

- 1-5 Express to 44th floor
- 6&7 Express to 107th floor
- 8-11 Express to 44th floor
- 12-23 Express to 78th floor

- 48 Servicing floors 1 - 40
- 49 Servicing floors 41 - 74
- 50 Servicing B-4 level - floor 108

**PASSENGER & FREIGHT ELEVATORS
IN TOWERS
Figure 4**

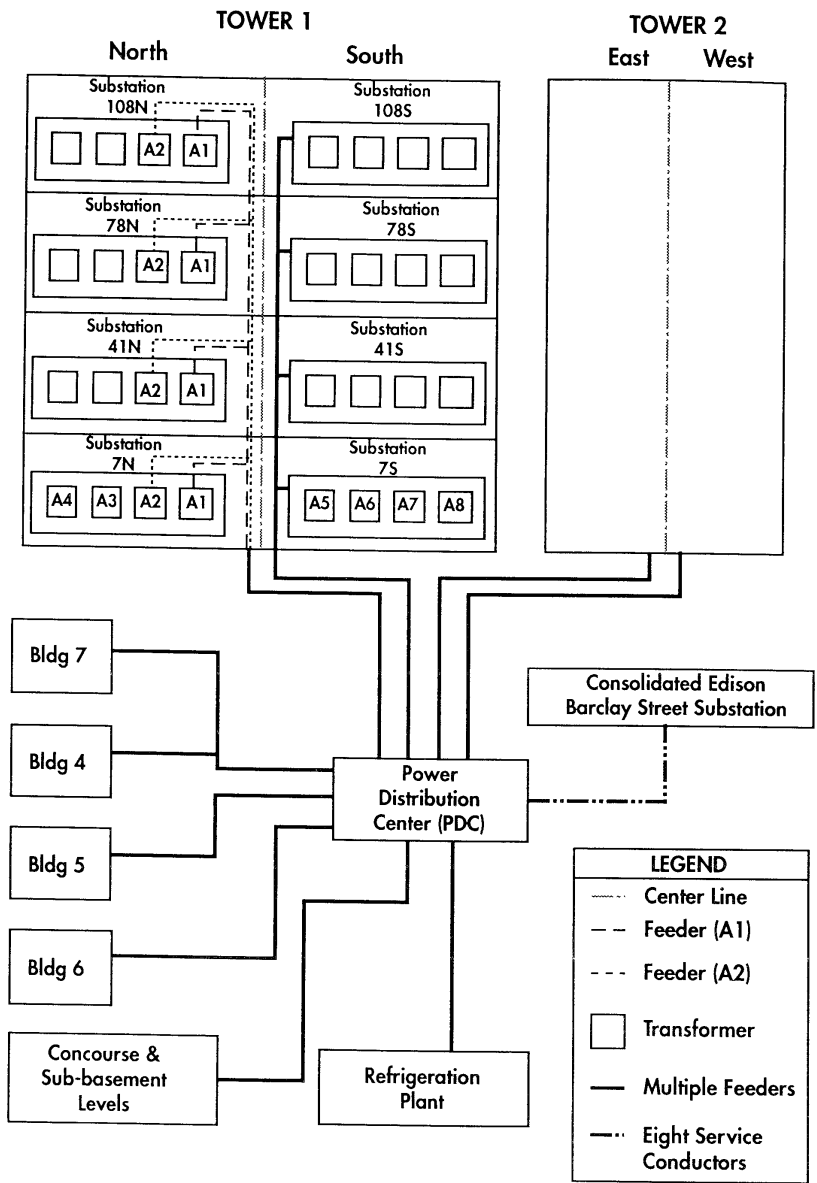

SIMPLIFIED ELECTRICAL SCHEMATIC
Figure 5

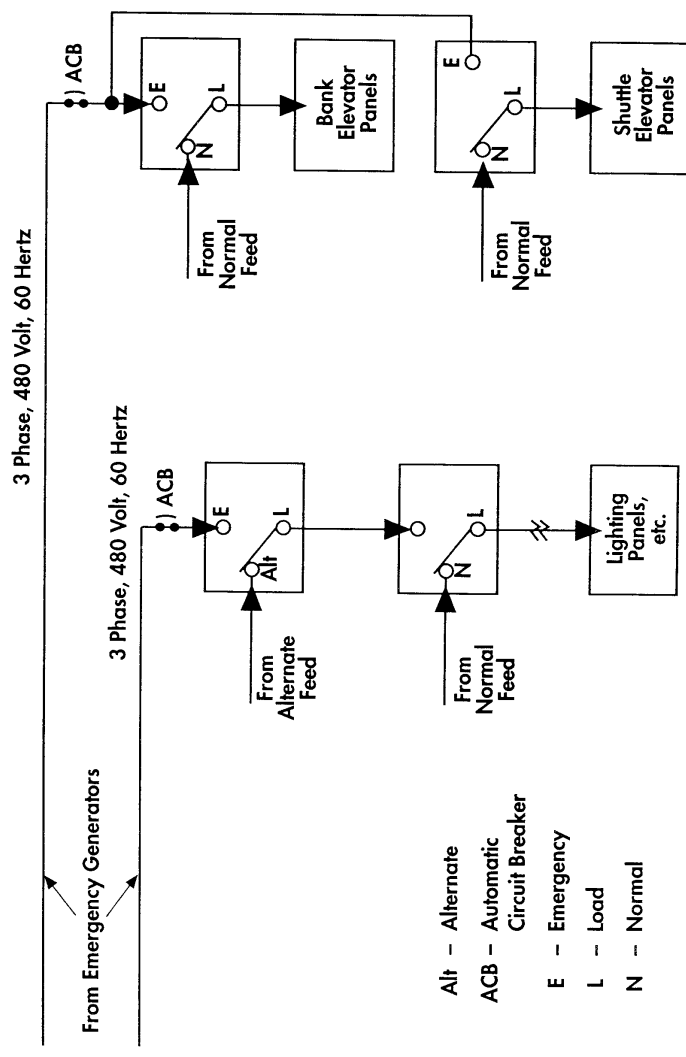

EMERGENCY ELECTRICAL SWITCHING
Simplified Schematic - Figure 6

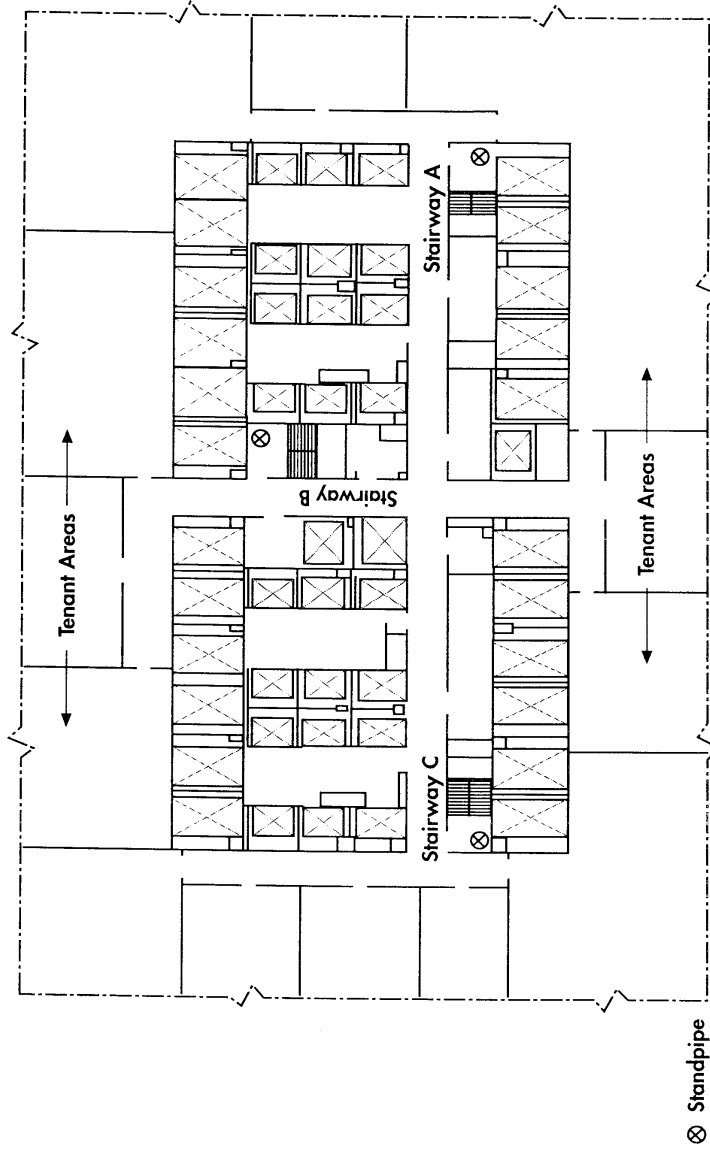

EXIT STAIRWAY LOCATIONS IN TOWER CORE AREA
Figure 7

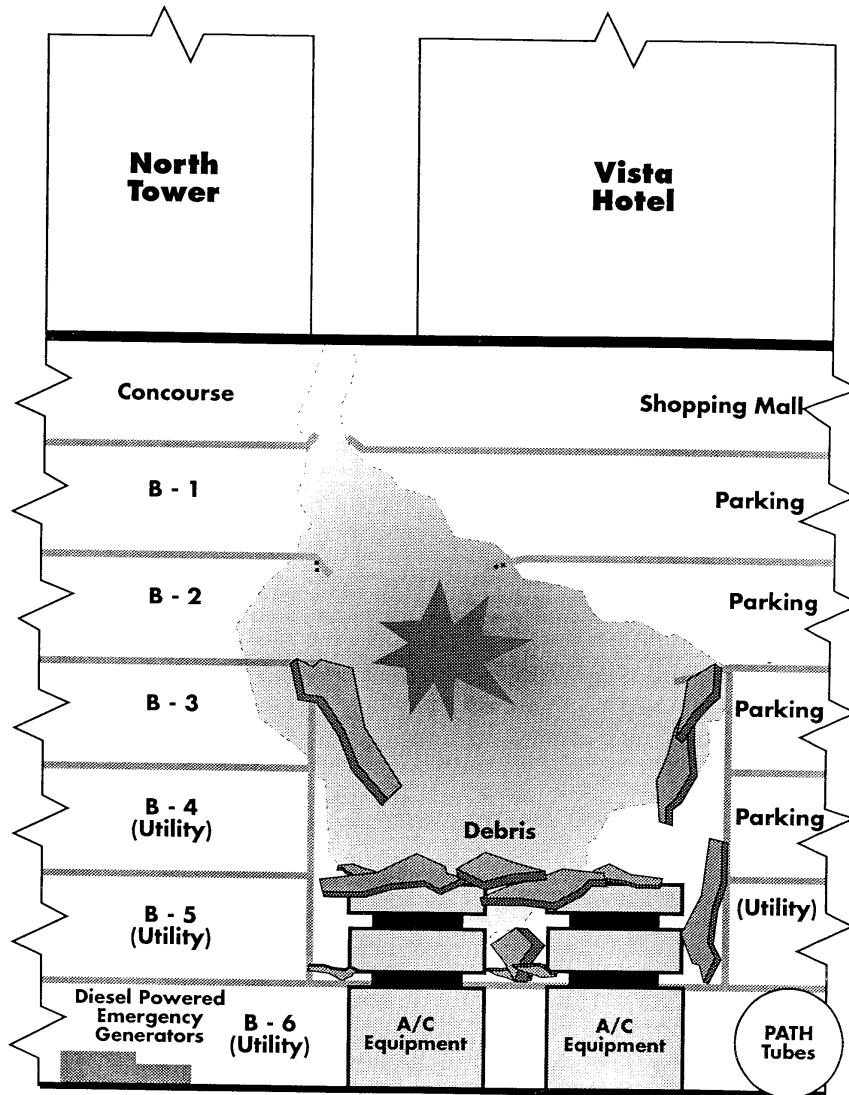

CONCOURSE & BASEMENT LEVELS
Figure 8

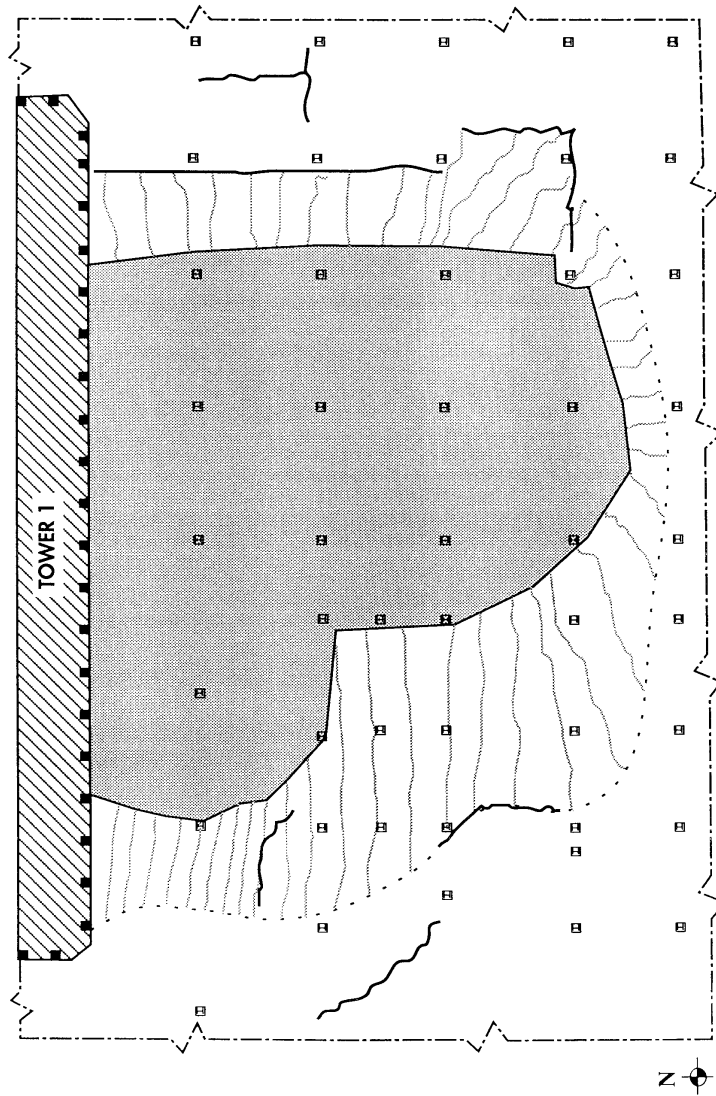





NOTES:

Column spacing is approx.
30 ft x 30 ft.

Tower 1 and Crater
Silhouettes are proportional.

DAMAGE TO B-2 FLOOR SLAB
Figure 9

-  Collapsed Slab
-  Sloping Slab
-  Collapsed Slab
-  Crack in Slab

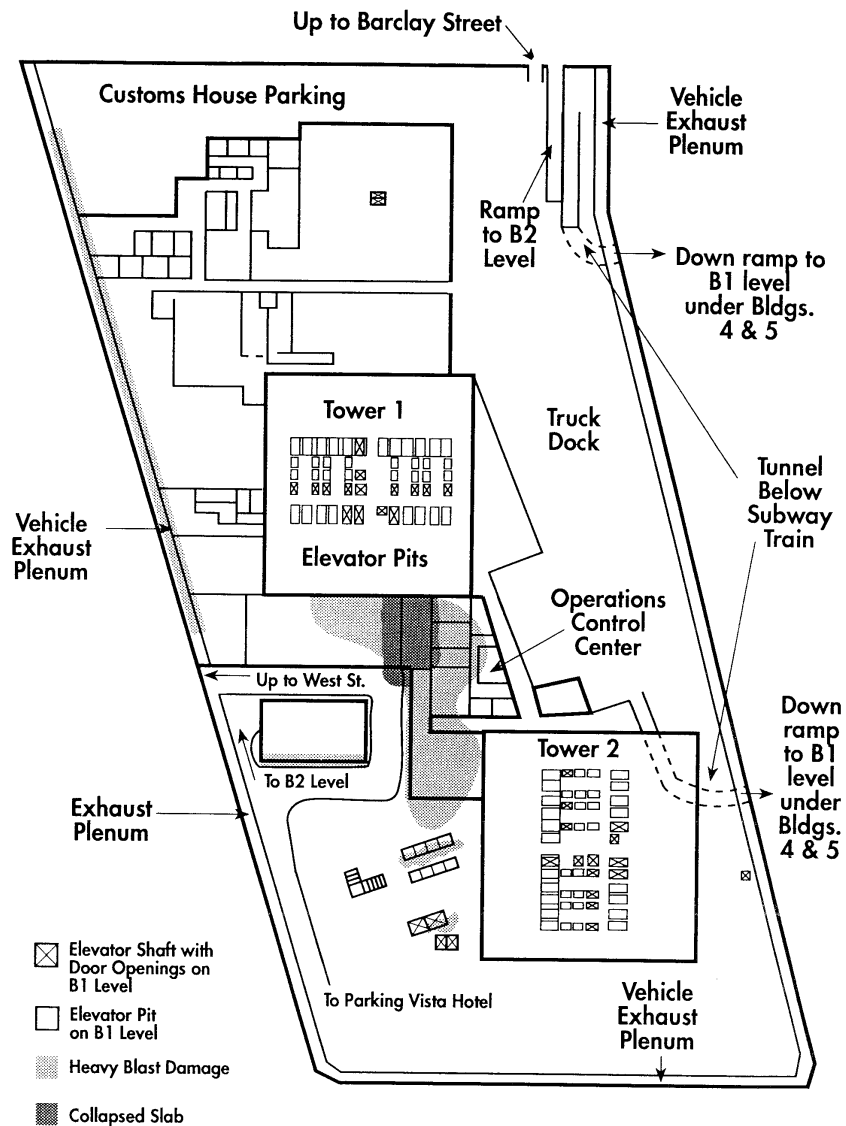

EXPLOSION DAMAGE, B1 LEVEL
Figure 10

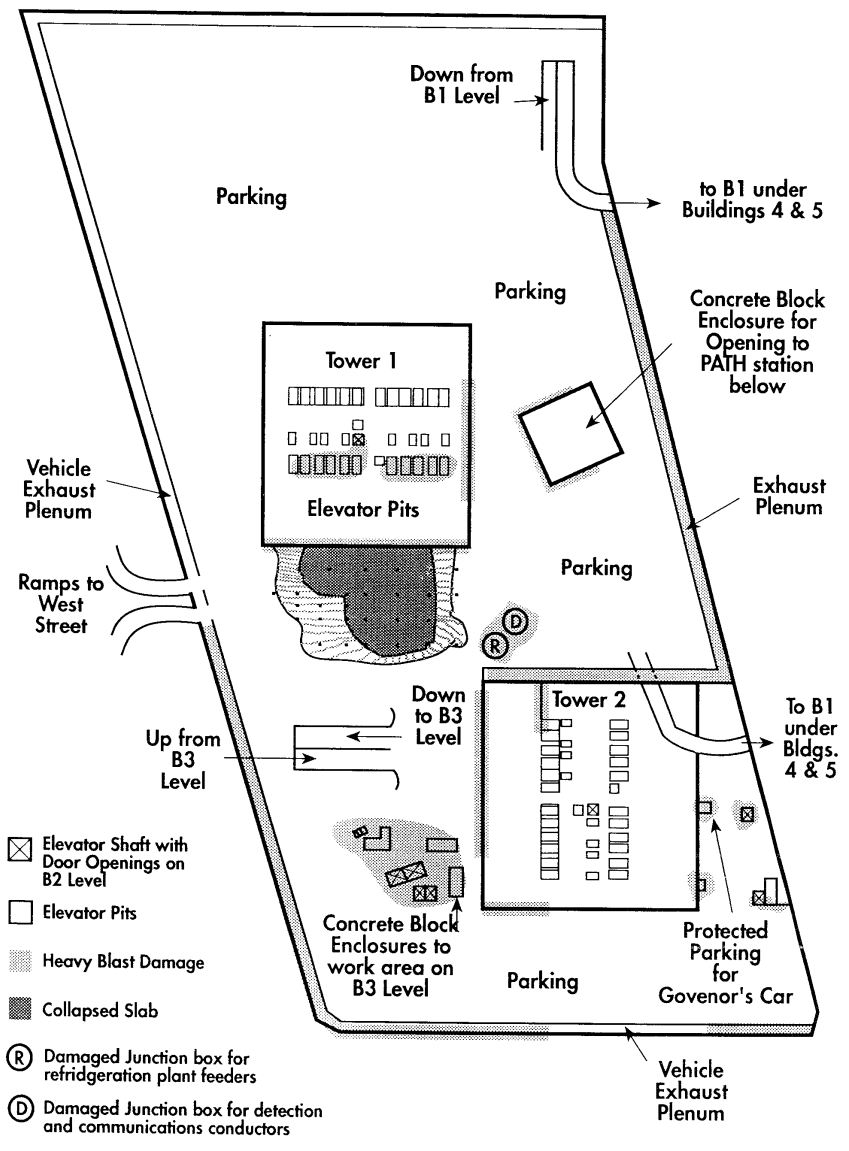

EXPLOSION DAMAGE, B2 LEVEL
Figure 11

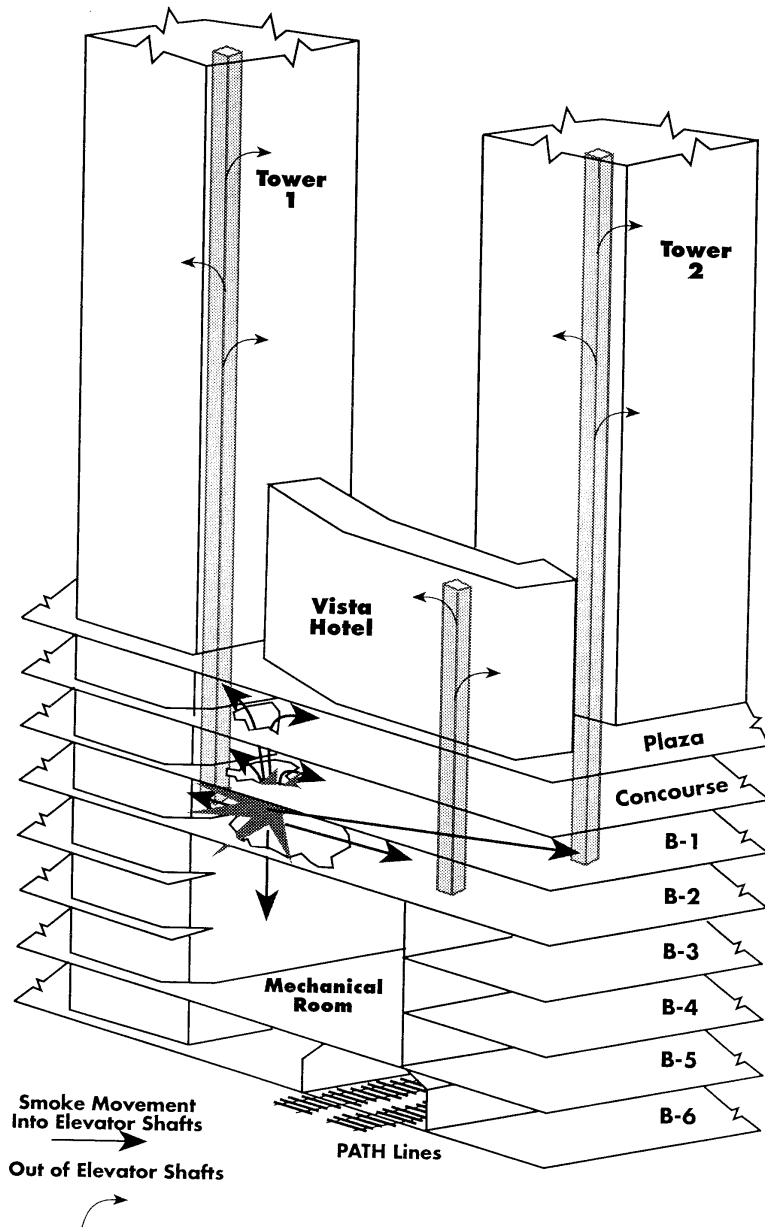

**WORLD TRADE CENTER
Figure 12**

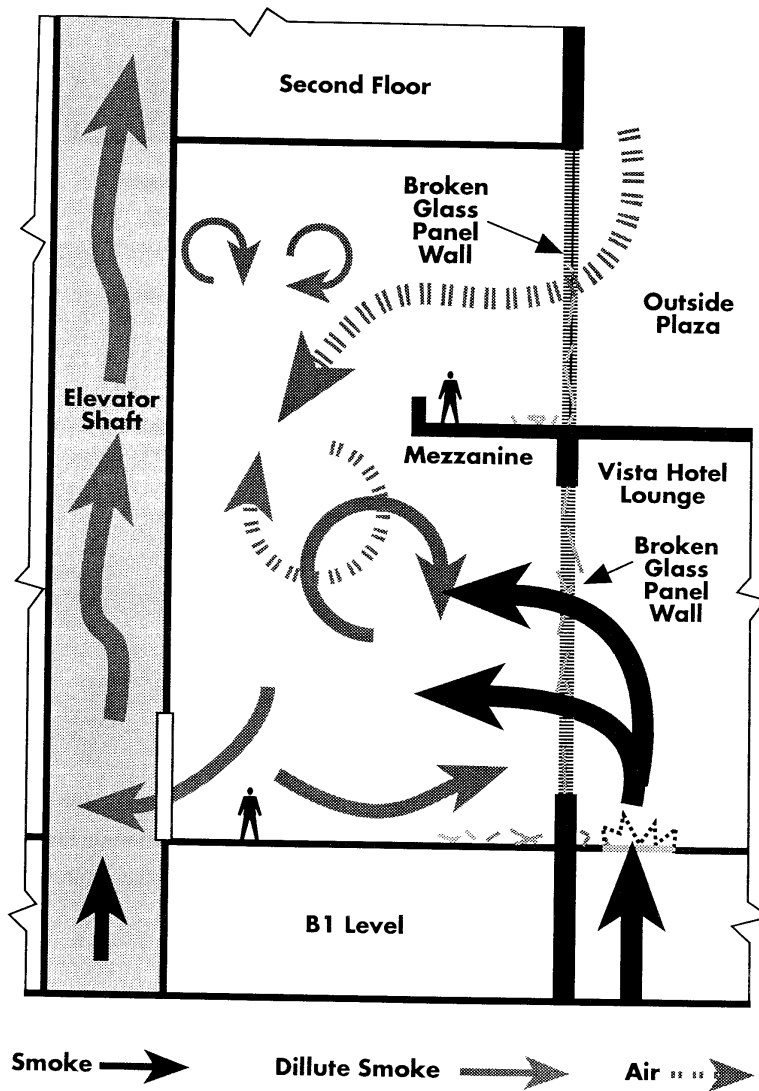

LOBBY: NORTH TOWER
Smoke Dillution and Movement
Figure 13